

# **ST. ANNE'S**

## **COLLEGE OF ENGINEERING & TECHNOLOGY**

ANGUCHETTYPALAYAM, PANRUTI  
Cuddalore District – 607 110.



### **EE 3611 – POWER SYSTEM SIMULATION LABORATORY**

NAME :  
REGISTER NO. :  
COURSE : B.E  
BRANCH : ELECTRICAL AND ELECTRONICS  
ENGINEERING  
YEAR & SEM : III YEAR - VISEM

# INDEX

S.No.	DATE	NAME OF THE EXPERIMENT	PAGE No.	REMARKS
1		Formation of Y Bus Matrix	01	
2		Formation of Z Bus Matrix	09	
3		Load Flow Analysis by Gauss – Seidal Method	19	
4		Load Flow Analysis by Newton – Raphson Method	31	
5		Fault Analysis	41	
6		Computation of Transmission Line Parameters	47	
7		Modeling of Transmission Line	51	
8		Load Frequency Control of Single Area System	55	
9		Load Frequency Control of Two Area System	63	
10		Transient Stability Analysis of Multi Machine Power System	69	
11		Small Signal Stability Analysis of Single Machine Infinite Bus System	75	
12		Economic Dispatch in Power System	81	

## FORMATION OF Y BUS MATRIX

### EXERCISE 1

#### AIM

To compute bus admittance matrix for the given power system network using MATLAB software package.

#### THEORY

Bus admittance matrix is often used in power system studies. In most of the power system studies, it is necessary to form Y-Bus matrix of the system by considering certain power system parameters depending upon the type of analysis.

For example, in load flow analysis, it is necessary to form Y-Bus matrix taking in to account only line data and not taking into account the generator impedance, transformer impedances or load impedances. In short circuit analysis, the generator transient reactance's and transformer leakage impedances must be taken into account in addition to line data during the computation of Y-bus matrix.

In stability analysis, line data, the generator transient reactances, transformer leakage impedances and equivalent load impedances to ground must be taken into account in computing Y-bus matrix. Y-Bus may be computed by inspection method, only if there is negligible mutual coupling between the lines. Every transmission line will be represented by the nominal  $\pi$  equivalent. Shunt admittances are added to the diagonal elements of Y-bus corresponding to the buses at which these are connected. The off diagonal elements are unaffected by shunt admittances. The equivalent circuit of tap - changing transformer may be considered in forming Y-Bus matrix, if tap changing transformers are present in the system.

The dimension of the [Y-Bus] matrix is  $(n \times n)$  where  $n$  is the total number of buses in the system other than reference bus which is the ground bus. In a power network, each bus is

connected only to a few other buses. So, the [Y-Bus] of a large network is highly sparse. This property is not evident in small systems, but in systems with hundreds of buses, the sparsity is high. It may be as high as 99%. Hence, by applying sparsity technique, numerical computation time as well as computer storage requirement may be drastically reduced.

### **FORMATION OF Y-BUS MATRIX**

$$\text{Generalized [Y-Bus]} = \begin{bmatrix} \mathbf{Y}_{ii} & \mathbf{Y}_{ij} \\ \mathbf{Y}_{ji} & \mathbf{Y}_{jj} \end{bmatrix}$$

Each diagonal term  $\mathbf{Y}_{ii}$  ( $i = 1, 2, \dots, n$ ) is called the self admittance or driving point admittance of bus  $i$  and equals the sum of all admittances terminating on the particular bus.

Each off-diagonal term  $\mathbf{Y}_{ij}$  ( $i, j = 1, 2, \dots, n; j \neq i$ ) is the transfer admittance between buses  $i$  and  $j$   $\mathbf{Y}_{ij} = -y_{ij}$ , where  $y_{ij}$  is net admittance connected between buses  $i$  and  $j$ ,  $n$  = total number of buses. Further,  $\mathbf{Y}_{ij} = \mathbf{Y}_{ji}$  on account of symmetry of Y-bus matrix.

### **ALGORITHM FOR FORMATION OF Y - BUS MATRIX**

Step (1) : Initialize [Y-Bus] matrix, that is replace all entries by zero

$$\mathbf{Y}_{ij} = \mathbf{Y}_{ij} - y_{ij} = \mathbf{Y}_{ji} = \text{off diagonal element}$$

Step (2) : Compute

$$\mathbf{Y}_{ii} = \left[ \sum_{\substack{j=1 \\ j \neq i}}^n y_{ij} \right] + y_{i0} = \text{diagonal element}$$

Where  $y_{i0}$  is the net bus to ground admittance connected at bus  $i$ .

FLOWCHART FOR FORMATION OF Y - BUS MATRIX

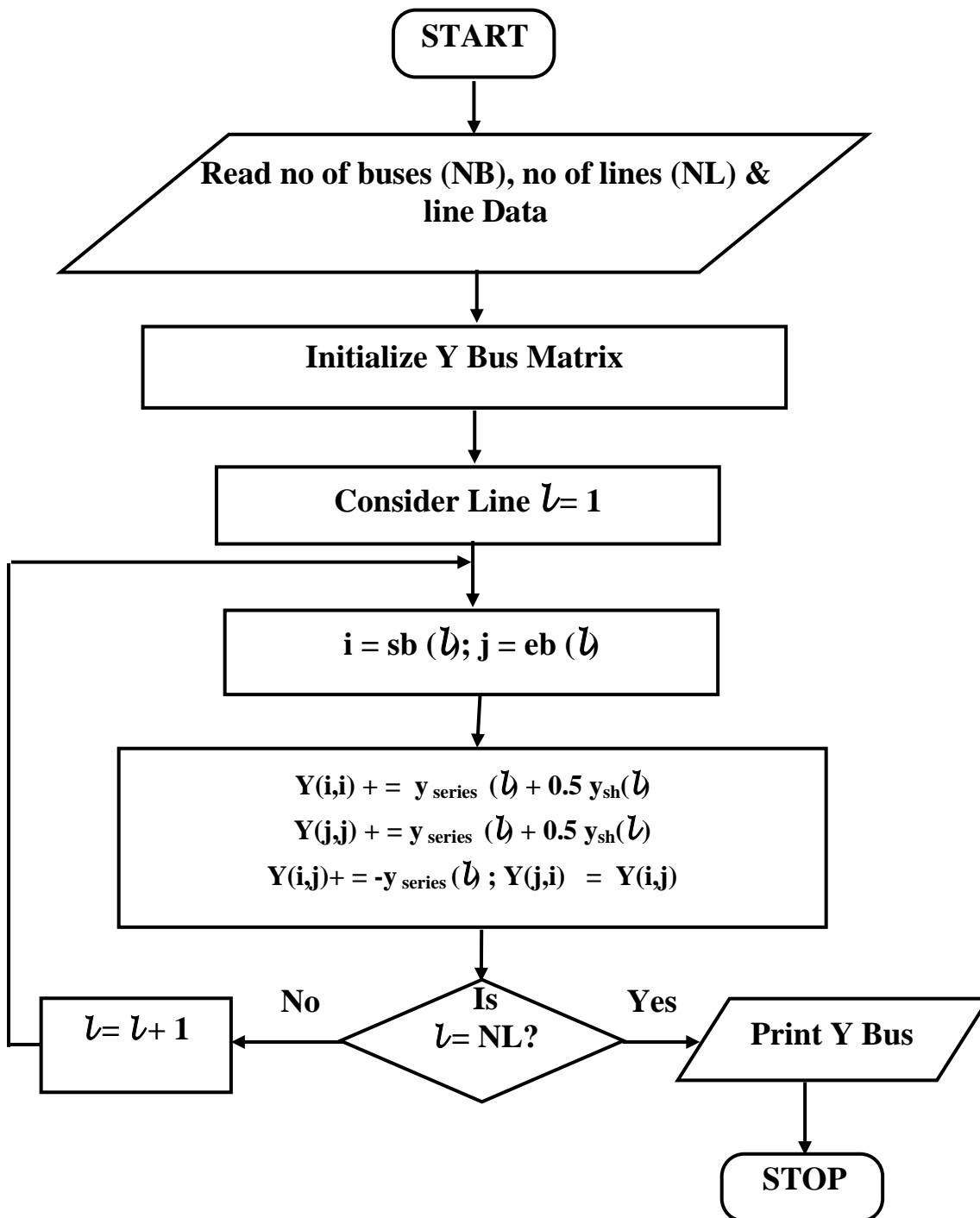

The [Y-Bus] matrix is formed by inspection method for a three-bus sample power system. The one line diagram and line data are given below.

**SINGLE - LINE DIAGRAM**

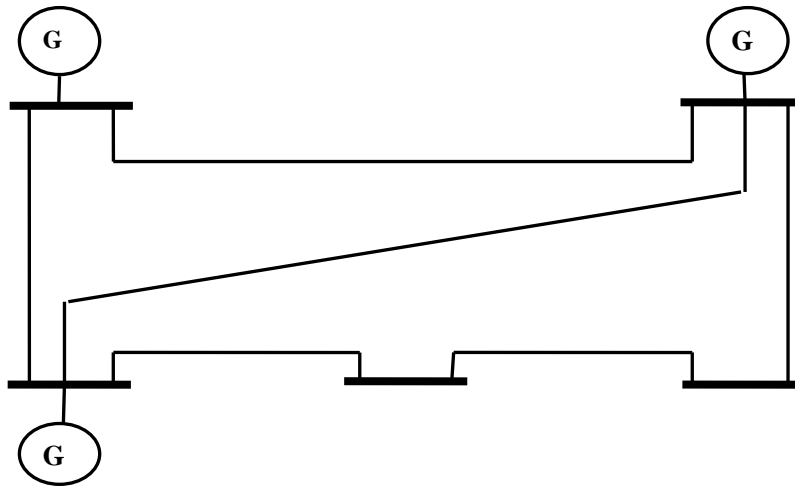

**Line Specification**

Line no.	Start bus	End bus	Series Impedance (P.U.)	Half-line charging admittance (P.U)	Rating (MW)
1	1	2	$0.001 + j0.01$	0.001	60
2	2	3	$0.002 + j0.02$	0.0005	40
3	3	4	$0.004 + j0.03$	0.0015	60
4	4	5	$0.003 + j0.01$	0.0001	60
5	5	1	$0.004 + j0.03$	0.0005	40
6	2	5	$0.001 + j0.04$	0.002	60









**ybus.m (Program for the Y-BUS formation)**

```
linedata = [1    1    2    0.001    0.01    0.001
            2    2    3    0.002    0.02    0.0005
            3    3    4    0.004    0.03    0.0015
            4    4    5    0.003    0.01    0.0001
            5    5    1    0.004    0.03    0.0005
            6    2    5    0.001    0.04    0.002];
```

```
fb = linedata(:,1);
tb = linedata(:,2);
r = linedata(:,3);
x = linedata(:,4);
b = linedata(:,5);
z = r + i*x;
y = 1./z;
b = i*b;
nbus = max(max(fb),max(tb));
nbranch = length(fb);
Y = zeros(nbus,nbus);
for k=1:nbranch
    Y(fb(k),tb(k)) = Y(fb(k),tb(k))-y(k);
    Y(tb(k),fb(k)) = Y(fb(k),tb(k));
end
for m =1:nbus
    for n =1:nbranch
        if fb(n) == m
            Y(m,m) = Y(m,m) + y(n)+ b(n);
        elseif tb(n) == m
            Y(m,m) = Y(m,m) + y(n) + b(n);
        end
    end
end
end
```

Y

**RESULT**

Thus for a given system bus admittance matrix was formulated using Mi – Power software package and the results were presented.

## FORMATION OF Z BUS MATRIX

### EXERCISE 2

#### AIM

To obtain the bus impedance matrix  $Z$  – bus of the given power system network using MATLAB software package.

#### THEORY

$Z$  - bus matrix is an important matrix used in different kinds of power system studies such as short circuit study, load flow study, etc.

In short circuit analysis, the generator and transformer impedances must be taken into account. In contingency analysis, the shunt elements are neglected while forming the  $Z$ -bus matrix, which is used to compute the outage distribution factors.

$Z$ -bus can be easily obtained by inverting the  $Y$ -bus formed by inspection method or by analytical method. Taking inverse of the  $Y$ -bus for large systems is time consuming; Moreover, modification in the system requires the whole process to be repeated to reflect the changes in the system. In such cases, the  $Z$ -bus is computed by  $Z$ -bus building algorithm.

**ALGORITHM FOR FORMATION OF Z-BUS MATRIX**

- Step 1 : Read the values such as number of lines, number of buses and line data, Generator data and Transformer data.
- Step 2 : Initialize  $Y_{bus}$  matrix.  $Y_{bus} [i] [j] = \text{complex} (0.0,0.0)$  for all values of  $i$  and  $j$
- Step 3 : Compute Y- bus Matrix by considering only line data.
- Step 4 : Modify the  $Y_{bus}$  matrix by adding the combined transformer and the generator admittances to the respective diagonal elements of Y- bus matrix.
- Step 5 : Compute the Z- bus matrix by inverting the modified  $Y_{bus}$  matrix.
- Step 6 : Check the inversion by multiplying modified  $Y_{bus}$  and Z-bus matrices to see whether the resulting matrix is unity matrix or not. If it is unity matrix, the result is correct.
- Step 7 : Print Z-bus matrix.

## FLOWCHART FOR FORMATION OF Z-BUS MATRIX

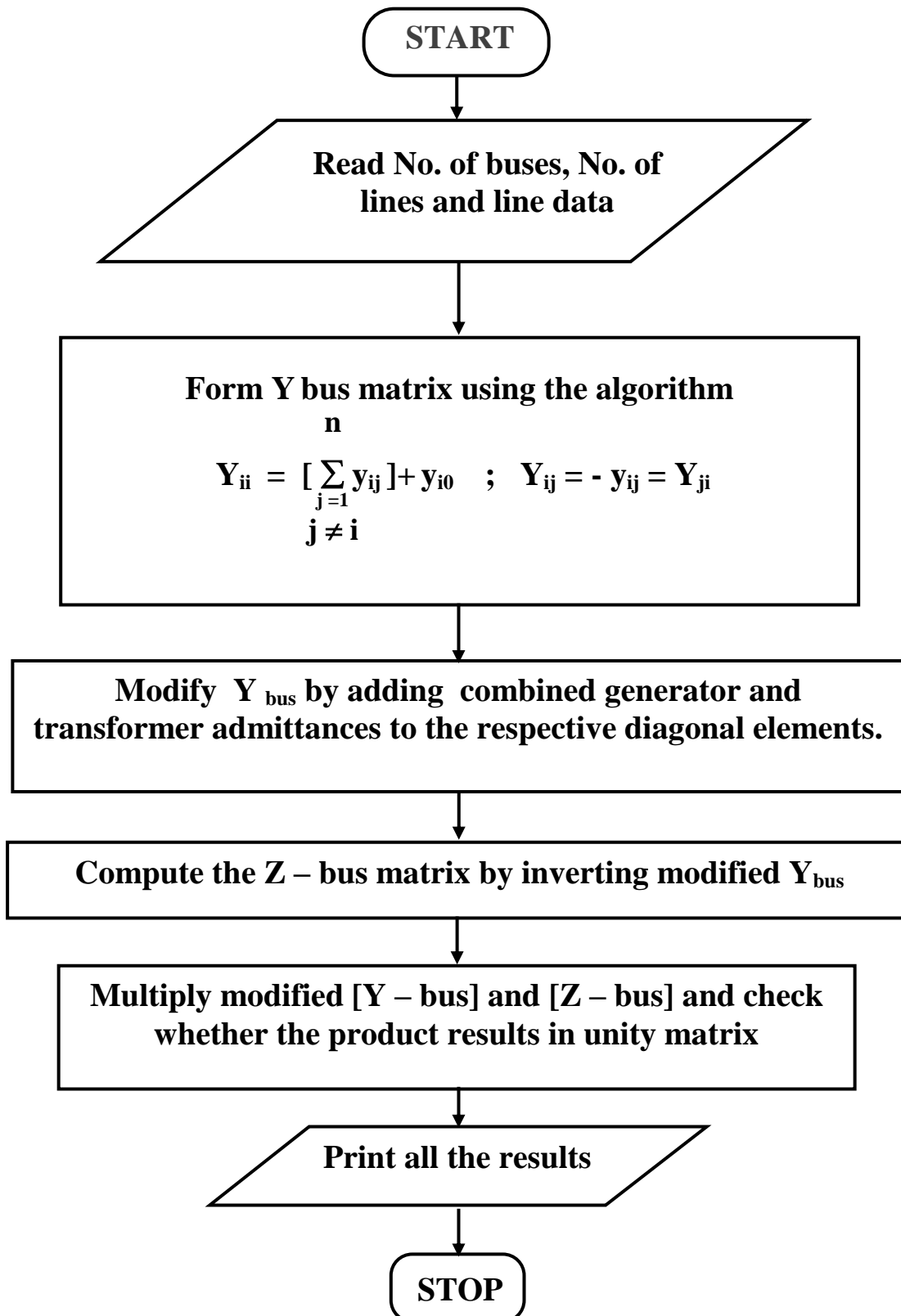

## **THEORY**

Z – bus matrix is an important matrix used in different kinds of power system studies such as short circuit study, load flow study, etc.

In short circuit analysis, the generator and transformer impedances must be taken into account. In contingency analysis, the shunt elements are neglected while forming the Z – bus matrix, which is used to compute the outage distribution factors.

This can be easily obtained by inverting the  $Y_{bus}$  formed by inspection method or by analytical method.

Taking inverse of the  $Y_{bus}$  for large systems is time consuming, more over, modification in the system requires the whole process to be repeated to reflect the changes in the system. In such cases, the Z – bus is computed by Z- bus building algorithm.

## **SIMULATION**

In this exercise, Z-bus for the system is developed by first forming the  $Y_{bus}$  and then inverting it to get the Z-bus matrix. The generator and transformer impedances are taken into account while forming the Y-bus matrix. Note that all loads should be neglected

Y-bus is a sparse matrix, Z-bus is a full matrix, i.e. zero elements of  $Y_{bus}$  become non-zero values in the corresponding Z-bus elements. The bus impedance matrix is most useful for short circuit studies.

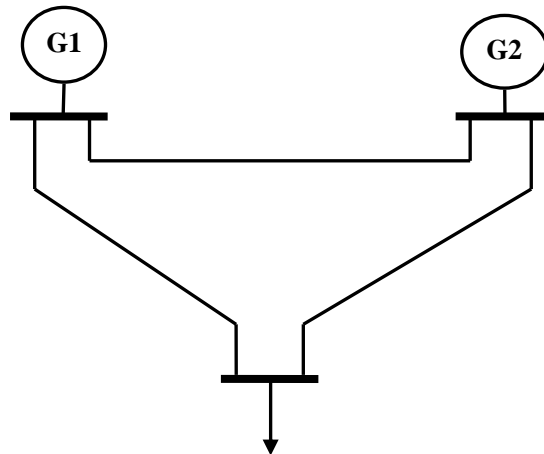

**Line Specification**

Line no.	Start bus	End bus	Series impedance (P.U.)	Half-line charging admittance (P.U.)	Rating MW
1	1	2	$0.001 + j 0.015$	0.001	60
2	2	3	$0.002 + j 0.021$	0.005	40
3	3	1	$0.004 + j 0.046$	0.0015	65

**Shunt element Details**

Bus	MVAR
3	50









**zbus.m (Program for Z-bus formation)**

```

linedata = [1      1      2      0.001      0.015      0.001
            2      2      3      0.002      0.021      0.0005
            3      3      1      0.004      0.046      0.0015 ];
fb = linedata(:,1);
tb = linedata(:,2);
r = linedata(:,3);
x = linedata(:,4);
b = linedata(:,5);
z = r + i*x;
y = 1./z;
b = i*b;

nbus = max(max(fb),max(tb));
nbranch = length(fb);
Y = zeros(nbus,nbus);

for k=1:nbranch
    Y(fb(k),tb(k)) = Y(fb(k),tb(k))-y(k);
    Y(tb(k),fb(k)) = Y(fb(k),tb(k));
end

for m =1:nbus
    for n =1:nbranch
        if fb(n) == m
            Y(m,m) = Y(m,m) + y(n)+ b(n);
        elseif tb(n) == m
            Y(m,m) = Y(m,m) + y(n) + b(n);
        end
    end
end
Y
zbus = inv(Y)

```

## RESULT

Thus for a given system bus impedance matrix was formulated using Mi – Power package.

## LOAD FLOW ANALYSIS BY GAUSS – SEIDAL METHOD

### EXERCISE 3

#### AIM

To conduct load flow analysis of a power system by Gauss – Seidal method using Mi  
- Power software package.

#### THEORY

##### Load flow study

This study helps in designing the power system network such that there are no overloads or over voltages or under voltages or excessive loss of power.

For each load condition, this analysis may be conducted so that the system performance will be good under all possible load conditions. The load flow analysis program computes the voltage magnitude, phase angles and transmission line power flow for a network under steady state operating condition.

The main objective of the study is to obtain the magnitude and phase angle of the voltage at each bus & Real and Reactive power in each line.

The load flow solution also gives the initial condition of the system when the transient behaviour of the system is to be studied. This study is essential to decide the best operation of the operating system and for planning the future expansion of the system. It is also essential for designing a new power system. This study is used for both Off-line and On-line analysis.

**Off-line Analysis :** Giving the data to computer as obtained from the data book.

**On-line Analysis :** Giving data to computer as obtained from the system (current data)

This analysis can be done in any one of the following ways

1. Gauss - Seidal method
2. Newton – Raphson method
3. Fast decoupled method

**PROBLEM FORMULATION (GAUSS-SEIDAL METHOD)**

The performance equation of a power system may be written as

$$[I_{BUS}] = [Y_{BUS}] [V_{BUS}] \quad (1)$$

Selecting one of the buses as the reference bus, we get (n-1) simultaneous equations.

The bus loading equations can be written as

$$I_i = \frac{P_i - jQ_i}{V_i^*} \quad (i = 1, 2, 3 \dots n) \quad (2)$$

$$P_i = \operatorname{Re} \left( \sum_{k=1}^n V_i^* Y_{ik} V_k \right) \quad (3)$$

$$Q_i = -\operatorname{Im} \left( \sum_{k=1}^n V_i^* Y_{ik} V_k \right) \quad (4)$$

**ADVANTAGE OF GAUSS – SEIDAL METHOD**

1. Simplicity of the technique
2. Small system memory requirement
3. Less computational time per iteration

### DISADVANTAGES OF GAUSS – SEIDAL METHOD

1. Slow rate of convergence, so large number of iterations
2. Number of iterations increases with increase in number of buses
3. Convergence Depends on choice of slack bus
4. Useful only for system having small number of buses

### ALGORITHM:

- Step 1 : Form Y-bus matrix
- Step 2 : Assume  $V_k = V_{k \text{ (spec)}} \angle 0^\circ$  at all generator buses.
- Step 3 : Assume  $V_k = 1 \angle 0^\circ = 1+j0$  at all load buses.
- Step 4 : Set iteration count = 1 (iter = 1)
- Step 5 : Let bus number  $i = 1$ .
- Step 6 : If 'i' refers to generator bus go to step no.7, otherwise go to step 8.
- Step 7a: If 'i' refers to the slack bus go to step 9. Otherwise go to step 7(b).
- Step 7b: Compute  $Q_i$  using

$$Q_i^{cal} = -\text{Im}[\sum_{j=1}^N V_i * Y_{ij} V_j]$$

$$Q_{Gi} = Q_i^{cal} + Q_{Li}$$

Check for Q limit violation

$$\text{If } Q_{i \text{ (min)}} < Q_{Gi} < Q_{i \text{ (max)}}, \text{ then } Q_{i \text{ (spec)}} = Q_i^{cal}$$

$$\text{If } Q_{Gi} < Q_{i \text{ (min)}}, \text{ then } Q_{i \text{ (spec)}} = Q_{i \text{ (min)}} - Q_{Li}$$

$$\text{If } Q_{Gi} > Q_{i \text{ (max)}}, \text{ then } Q_{i \text{ (spec)}} = Q_{i \text{ (max)}} - Q_{Li}$$

If  $Q_{\text{limit}}$  is violated, then treat this bus as P-Q bus till convergence is obtained.

Step 8 : Compute  $V_i$  using the equation,

$$V_i^{\text{new}} = \frac{1}{Y_{ii}} \left[ \frac{P_i - jQ_i}{V_i^{\text{old}*}} - \sum_{i=1}^{j-1} Y_{ij} V_j^{\text{new}} - \sum_{i=j+1}^n Y_{ij} V_i^{\text{old}} \right]$$

Step 9 : If  $i$  is less than the number of buses, increment  $i$  by 1 and go to step 6.

Step 10: Compare two successive iteration values for  $V_i$

If  $V_i^{\text{new}} - V_i^{\text{old}} < \text{tolerance}$ , go to step 12.

Step 11: Update the new voltage as

$$V^{\text{new}} = V^{\text{old}} + \alpha (V^{\text{new}} - V^{\text{old}})$$

$$V^{\text{old}} = V^{\text{new}}$$

iter = iter + 1; go to step 5

Step 12: Compute relevant quantities.

$$\text{Slack bus power, } S_i = P_i - jQ_i = V * I = \sum_{j=1}^N Y_{ij} V_j$$

$$\text{Line flow, } S_{ij} = P_{ij} + jQ_{ij}$$

$$= V_i [V_i^* - V_j^*] Y_{ij}^* + |V_i|^2 Y_{ii}^*$$

$$P_{\text{Loss}} = P_{ij} + P_{ji}$$

$$Q_{\text{Loss}} = Q_{ij} + Q_{ji}$$

Step 13: Stop the execution.



FLOW CHART FOR THE GAUSS-SEIDAL LOAD FLOW ANALYSIS

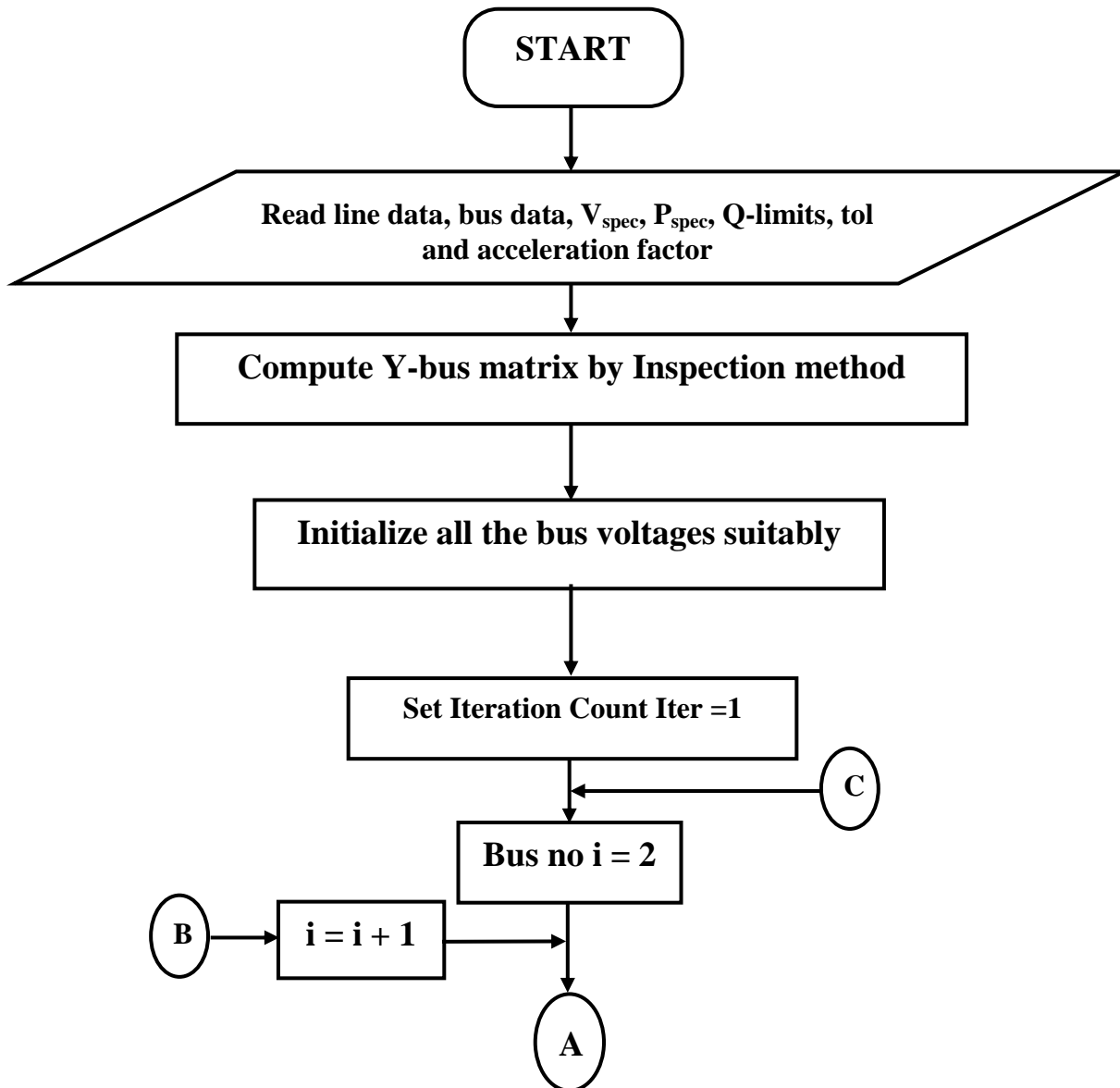

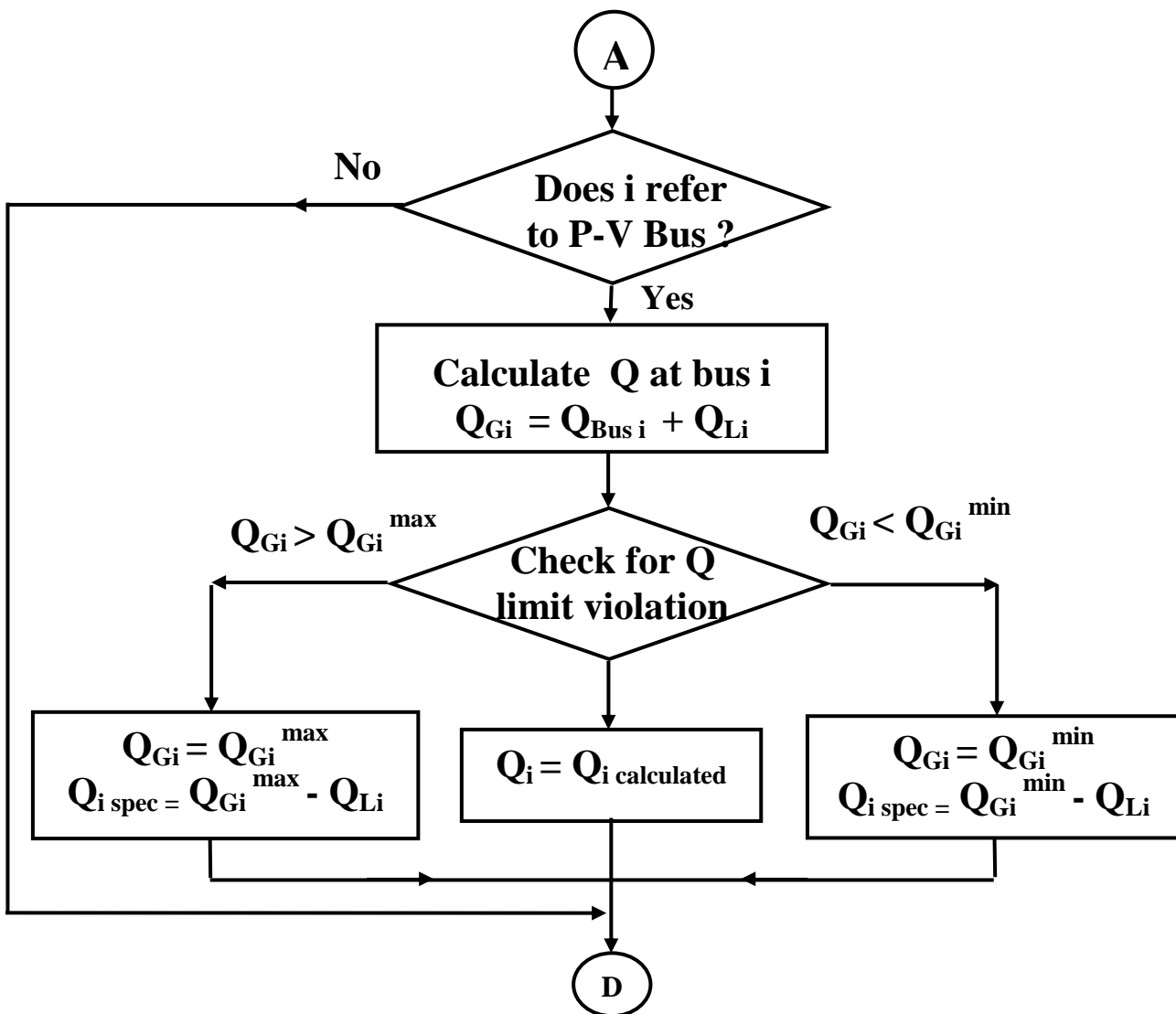

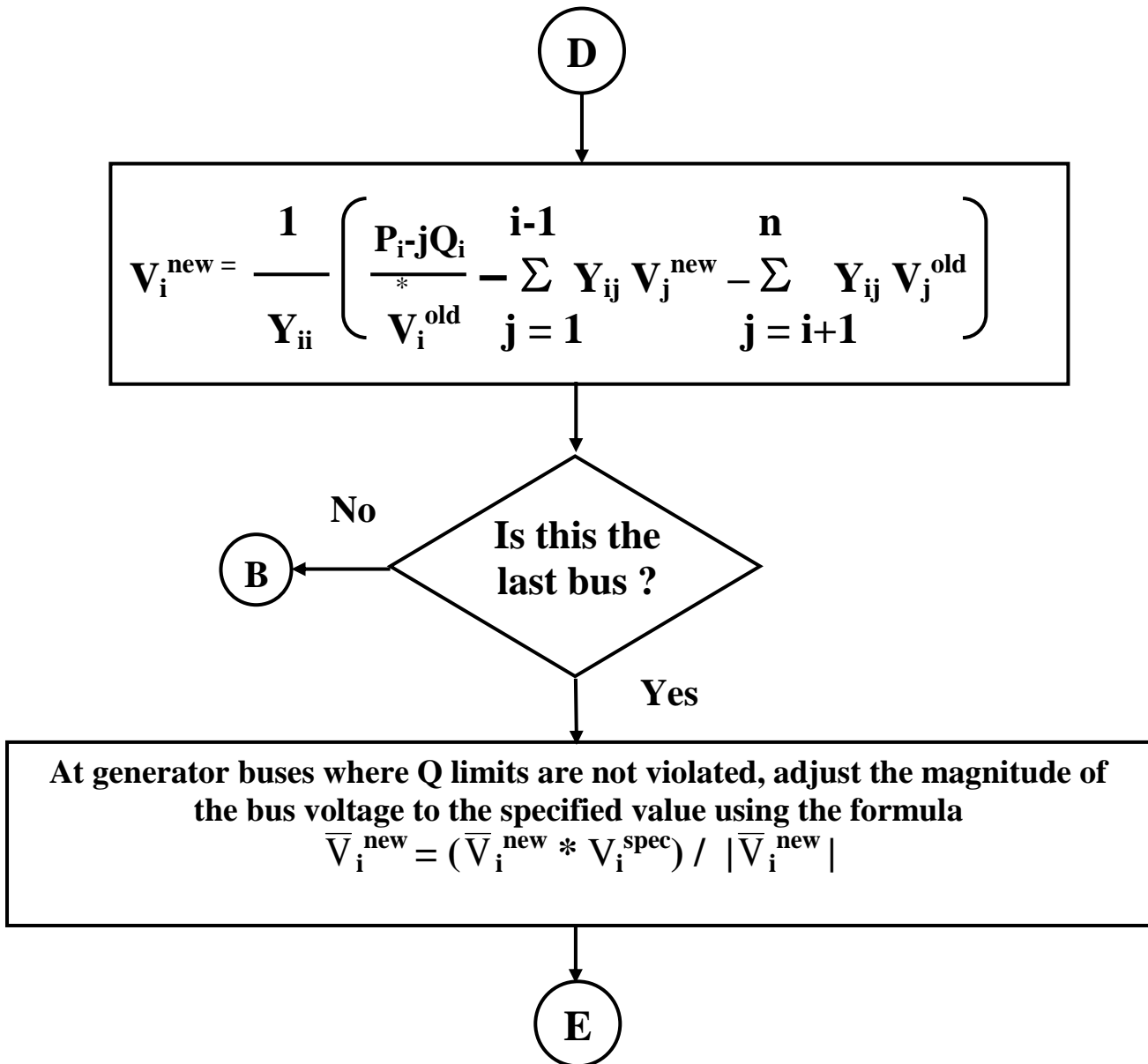

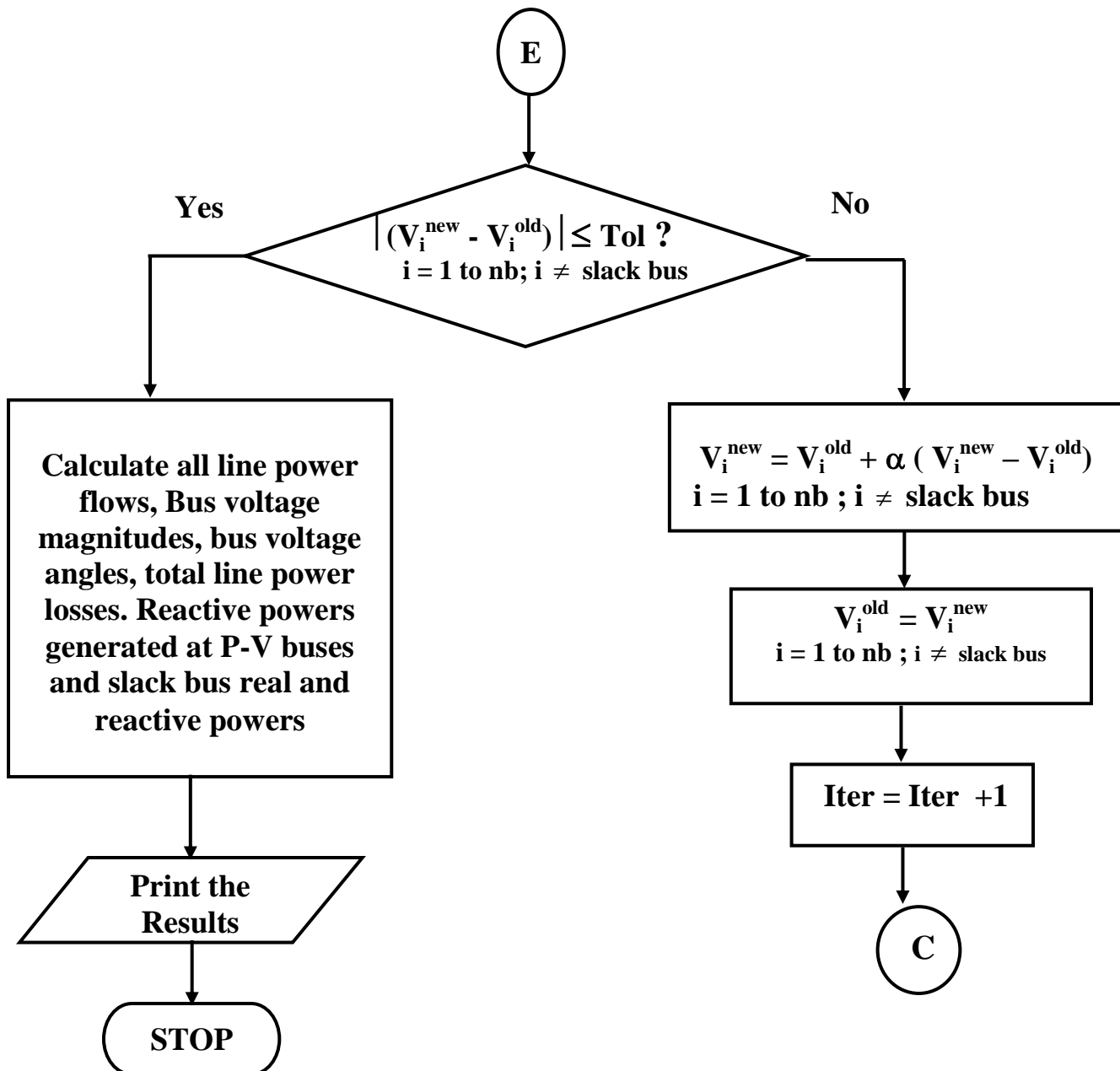

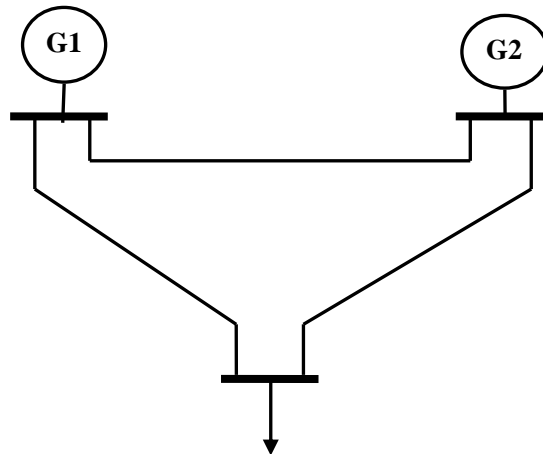

**Bus Specifications:**

Bus no	Bus type	V spec	Generation (P.U)		Load (P.U)		Q-min	Q-max
			P	Q	P	Q		
1	Slack	1.06	-	-	-	-	-	-
2	P-V	1.02	0.6	0.25	0.0	0.0	0.25	0.75
3	P-Q	1.0	-	-	0.75	0.35	-	-

**Line Data**

Line. No	Start bus	End bus	Series impedance	Half-line charging admittance	Capacity [MW]
1	1	2	$0.002 + j0.02$	0.0001	70
2	2	3	$0.003 + j0.032$	0.0002	64
3	1	3	$0.0015 + j0.0035$	0.00015	55

**Shunt Element Data**

S.No	Bus. No	MVAR
1	3	4.0





## **RESULT**

Load flow study of the given power system using Mi - Power software package is carried out by applying Gauss – Seidal method. The results are presented



## LOAD FLOW ANALYSIS BY NEWTON – RAPHSON METHOD

### EXERCISE 4

#### AIM

To conduct load flow analysis of a power system by Newton \_ Raphson method using Mi - Power software package.

#### THEORY:

##### Load flow study

This study helps in designing the power system network such that there are no overloads or over voltages or under voltages or excessive loss of power.

For each load condition, this analysis may be conducted so that the system performance will be good under all possible load conditions. The load flow analysis program computes the voltage magnitude, phase angles and transmission line power flow for a network under steady state operating condition.

The main objective of the study is to obtain the magnitude and phase angle of the voltage at each bus & Real and Reactive power in each line.

The load flow solution also gives the initial condition of the system when the transient behaviour of the system is to be studied. This study is essential to decide the best operation of the operating system and for planning the future expansion of the system. It is also essential for designing a new power system. This study is used for both Off-line and On-line analysis.

**Off-line Analysis :** Giving the data to computer as obtained from the data book.

**On-line Analysis :** Giving data to computer as obtained from the system (current data)

This analysis can be done in any one of the following ways

1. Gauss - Seidal method
2. Newton – Raphson method
3. Fast decoupled method

### **LOAD FLOW SOLUTION BY NEWTON-RAPHSON METHOD**

The N-R technique converges equally fast for small as well as large system, usually less than 4 or 5 iterations but more functional evaluations are required. It has become very popular for large system studies.

The most widely used methods for solving simultaneous non linear algebraic equations is the N-R method. This method is a successive approximation procedure based on initial estimate of the unknown and the use of Taylor series expansion. In this method the Real and Imaginary part of power can be represented as

$$P_i = \sum_{j=1}^N |V_i| |Y_{ij}| |V_j| \cos (\theta_{ij} + \delta_j - \delta_i) \quad (1)$$

$$Q_i = - \sum_{j=1}^N |V_i| |Y_{ij}| |V_j| \sin (\theta_{ij} + \delta_j - \delta_i) \quad (2)$$

#### **ALGORITHM:**

Step 1 :        Form Y-bus matrix

Step 2 :        Assume flat start for starting voltage solution

$$\delta_i^0 = 0.0, \quad \text{for } i = 1, \dots, N \text{ for all buses except slack bus.}$$

$$|V_i^0| = 1.0, \quad \text{for } i = M+1, M+2, \dots, N \text{ (for all PQ buses)}$$

$$|V_i| = |V_i^0|_{(spec)} \quad \text{for all PV buses and slack bus}$$

Step 3 :        For load buses, calculate  $P_i^{cal}$  and  $Q_i^{cal}$ .

Step 4 :        For PV buses, check for Q – limit violation.

If  $Q_{i(\min)} < Q_i^{cal} < Q_{i(\max)}$ , then bus acts as PV bus.

If  $Q_i^{cal} < Q_{i(\min)}$ , then  $Q_{i(\text{spec})} = Q_{i(\min)}$

If  $Q_i^{cal} > Q_{i(\max)}$ , then  $Q_{i(\text{spec})} = Q_{i(\max)}$

The P-V bus will act as P-Q bus.

Step 5 : Compute mismatch vector using

$$\Delta P_i = P_{i \text{ spec}} - P_i^{cal}$$

$$\Delta Q_i = Q_{i \text{ spec}} - Q_i^{cal}$$

Step : 6 Compute  $\Delta P_i = \max |\Delta P_i|$  ;  $i = 1, 2, \dots, N$  except slack bus

$$\Delta Q_i = \max |\Delta Q_i| ; i = M+1, \dots, N$$

Step : 7 Compute jacobian matrix using

$$J = \begin{bmatrix} \frac{\partial P_i}{\partial \delta} & \frac{\partial P_i}{\partial |V|} \\ \frac{\partial Q_i}{\partial \delta} & \frac{\partial Q_i}{\partial |V|} \end{bmatrix}$$

Step : 8 Obtain state correction vector

$$\begin{bmatrix} \Delta \delta \\ \Delta V \end{bmatrix} = [J]^{-1} \begin{bmatrix} \Delta P \\ \Delta Q \end{bmatrix}$$

Step : 9 Update state vector using

$$V^{new} = V^{old} + \Delta V$$

$$\delta^{new} = \delta^{old} + \Delta \delta$$

Step : 10 This procedure is continued until

$$|\Delta P_i| < \epsilon \text{ and } |\Delta Q_i| < \epsilon, \text{ otherwise go to step 3.}$$

**FLOWCHART FOR THE NEWTON-RAPHSON METHOD**

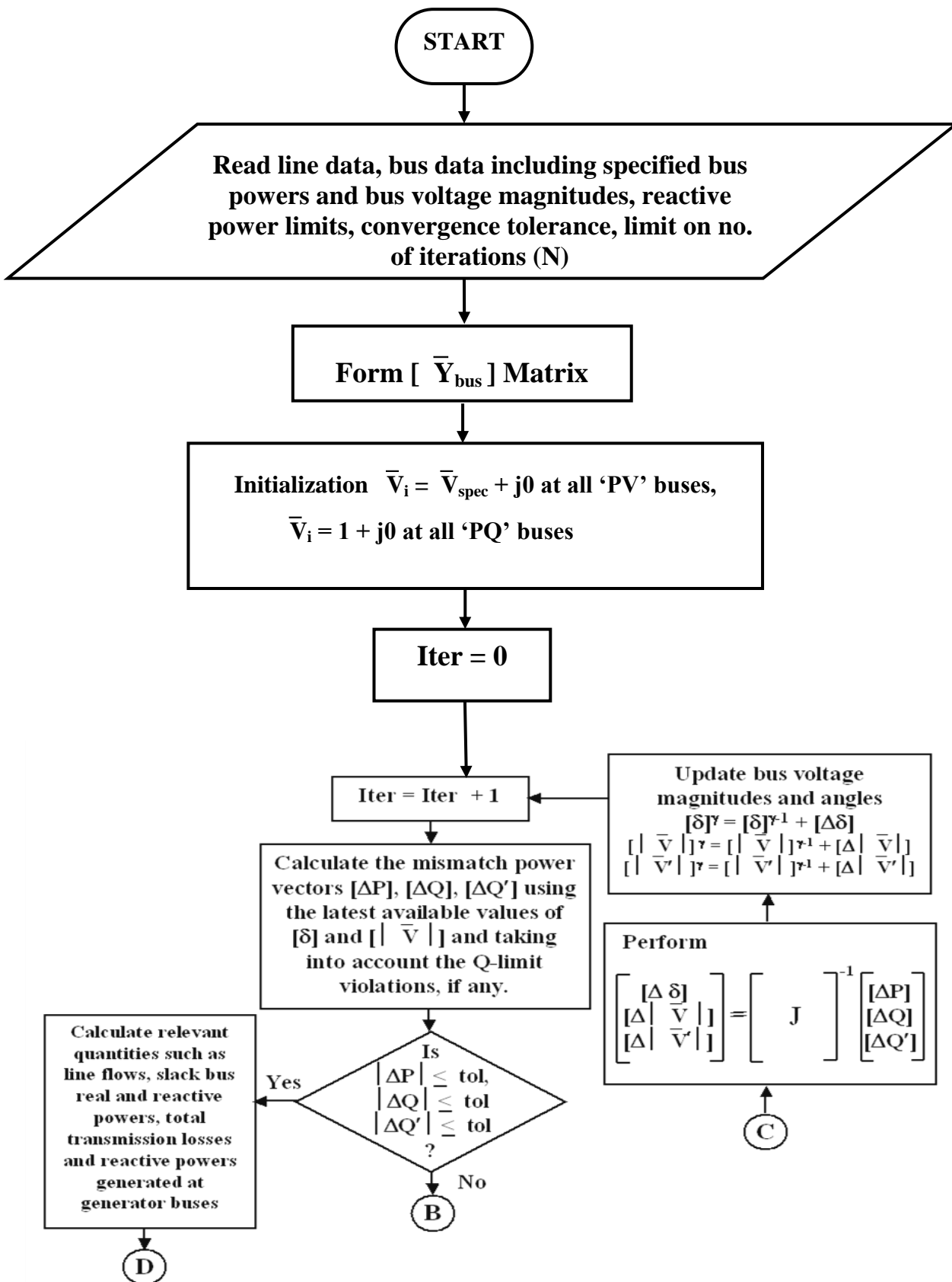

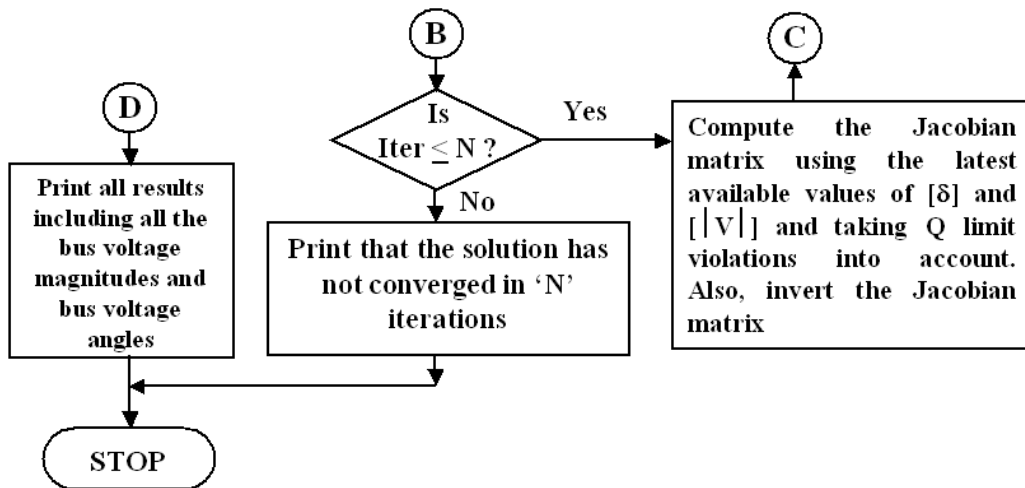

### ADVANTAGES

1. On account of its quadratic convergence, Newton- Raphson method is mathematically superior to the Gauss – seidal method and is less prone to divergence with ill conditioned systems
2. More efficient and practical for large power systems
3. Number of iterations is independent of the system size
4. More accuracy and convergence is assured
5. This method is insensitive to factors like slack bus selection, regulating transformers etc.,

### DISADVANTAGES

1. Solution technique is difficult
2. More computations are involved and hence computing time per iteration is large
3. Computer memory requirement is more

**SINGLE LINE DIAGRAM**

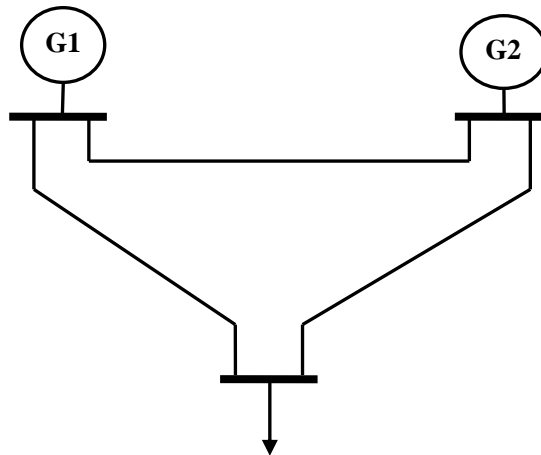

**Bus Specifications:**

Bus no	Bus type	V spec	Generation (P.U.)		Load (P.U.)		Q-min	Q-max
			P	Q	P	Q		
1	Slack	1.06	-	-	-	-	-	-
2	P-V	1.02	0.6	0.2	0.0	0.0	0.3	0.7
3	P-Q	1.0	-	-	0.8	0.62	-	-

**Line Data**

Line. No	Start bus	End bus	Series impedance	Half-line charging admittance	Capacity [MW]
1	1	2	$0.002 + j0.02$	0.0001	70
2	2	3	$0.003 + j0.032$	0.0001	64
3	1	3	$0.0015 + j0.0035$	0.00015	55









## RESULT

Load flow study of the given power system using Mi - Power software package is carried out by applying Newton - Raphson method. The results are presented.

## FAULT ANALYSIS

### EXERCISE : 5

#### AIM:

To find out the fault current for single line to ground fault.

#### THEORY:

The single line to ground fault the most common type is caused by lightning or by conductors making contact with grounded structures. Figure shows a three phase generator with neutral grounded through impedance,  $Z_n$ .

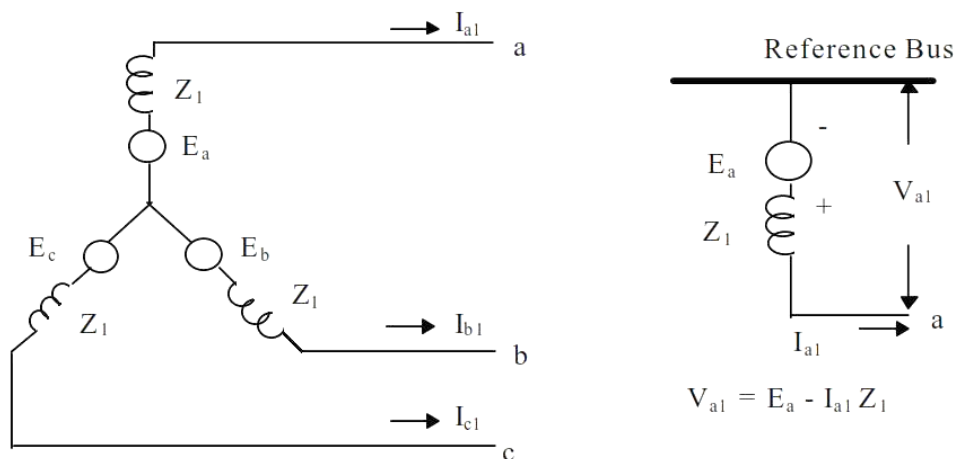

Suppose a LG fault occur on phase 'a' connected through impedance  $Z_n$ .

Assuming the generator is initially on no-load the conduction at the fault bus 'k' are expressed by the following relation.

$$V_a = Z_f I_a$$

$$I_b = I_c = 0 \tag{1}$$

$$I_f = I_a$$

$$\begin{bmatrix} I_a^0 \\ I_a^+ \\ I_a^- \end{bmatrix} = \frac{1}{3} \begin{bmatrix} 1 & 1 & 1 \\ 1 & a & a^2 \\ 1 & a^2 & a \end{bmatrix} \begin{bmatrix} I_a \\ I_b \\ I_c \end{bmatrix} \tag{2}$$

Substitute  $I_b = I_c = 0$  the symmetrical components of current are,

$$\begin{bmatrix} I_a^0 \\ I_a^+ \\ I_a^- \end{bmatrix} = \frac{1}{3} \begin{bmatrix} 1 & 1 & 1 \\ 1 & a & a^2 \\ 1 & a^2 & a \end{bmatrix} \begin{bmatrix} I_a \\ 0 \\ 0 \end{bmatrix} \quad (3)$$

From the equation (3) we find that

$$\begin{aligned} I_a^0 &= I_a/3 \\ I_a^+ &= I_a/3 = I_f/3 \\ I_a^- &= I_a/3 \\ I_a^0 &= I_a^+ = I_a^- = I_a/3 = I_f/3 \end{aligned} \quad (4)$$

From the sequence network of the generator the symmetrical voltages are given by

$$\begin{bmatrix} V_a^0 \\ V_a^+ \\ V_a^- \end{bmatrix} = \begin{bmatrix} 0 \\ E_a \\ 0 \end{bmatrix} - \begin{bmatrix} Z_{kk}^0 & 0 & 0 \\ 0 & Z_{kk}^+ & 0 \\ 0 & 0 & Z_{kk}^- \end{bmatrix} \begin{bmatrix} I_a^0 \\ I_a^+ \\ I_a^- \end{bmatrix}$$

$$\begin{aligned} V_a^0 &= -Z_{kk}^0 I_a^0 = -Z_{kk}^0 I_a^+ \\ V_a^- &= -Z_{kk}^- I_a^- = -Z_{kk}^- I_a^+ \\ V_a^+ &= E_a - Z_{kk}^+ I_a^+ \end{aligned} \quad (5)$$

The phase voltages are given by

$$\begin{bmatrix} V_a \\ V_b \\ V_c \end{bmatrix} = \begin{bmatrix} 1 & 1 & 1 \\ 1 & a & a^2 \\ 1 & a^2 & a \end{bmatrix} \begin{bmatrix} V_a^0 \\ V_a^+ \\ V_a^- \end{bmatrix} \quad (6)$$

From equation (6)  $V_a = V_a^0 + V_a^+ + V_a^-$

From condition  $V_a = Z_f \cdot I_a$  (7)

Sub Symmetrical components of voltages from equation (5) we get

$$-Z_{kk}^0 I_a^+ + E_a - Z_{kk}^+ I_a^+ - Z_{kk}^- I_a^+ = Z_f \cdot I_a$$

$$E_a - I_a^+ (Z_{kk}^0 + Z_{kk}^+ + Z_{kk}^-) = Z_f \cdot 3 I_a^+$$

$$I_a^+ (Z_{kk}^0 + Z_{kk}^+ + Z_{kk}^-) + Z_f \cdot 3 I_a^+ = E_a$$

$$I_a^+ (Z_{kk}^0 + Z_{kk}^+ + Z_{kk}^- + 3Z_f) = E_a$$

$$I_a^+ = \frac{E_a}{(Z_{kk}^0 + Z_{kk}^+ + Z_{kk}^- + 3Z_f)} \quad (8)$$

$$\text{The fault current } I_f = I_a = 3 I_a^+ = \frac{3E_a}{(Z_{kk}^0 + Z_{kk}^+ + Z_{kk}^- + 3Z_f)} \quad (9)$$

On sub symmetrical components of current in equation (5) and (6) the symmetrical components of voltages and phase voltages at the fault are obtained.

**SEQUENCE NETWORK:**

From equation (4) and (5), the +ve sequence, -ve sequence and zero sequence network are connected in series as shown in fig. Thus for a LG fault, the thevnin impedance at the fault impedance is obtained for each sequence network and are connected in series.

Mostly  $Z_{kk}^+ = Z_{kk}^-$

If the generator is solidly grounded, then for solid short circuit fault

$Z_f = 0.$

If the neutral of the generator is ungrounded the zero sequence network is open circuited.

$$I_a^0 = I_a^+ = I_a^- = 0$$

And  $I_f = 0$

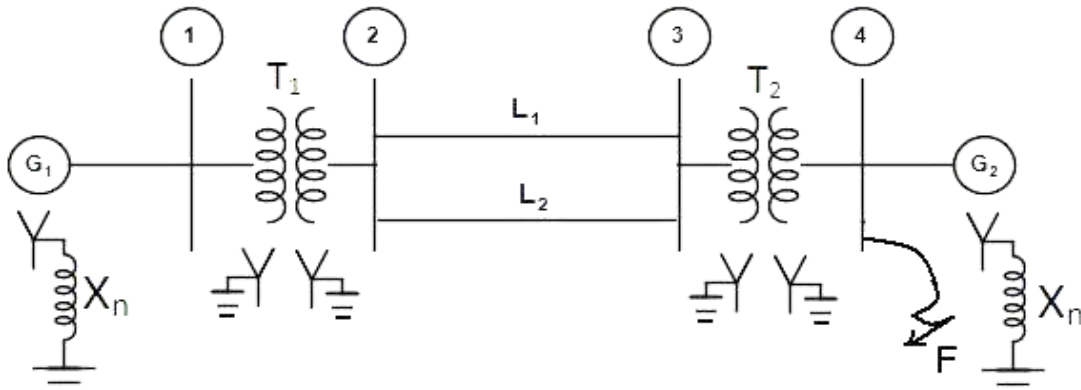

**DATA:**

$G_1, G_2$  : 100 MVA, 11 KV,  $X^+ = X^- = 15\%$ ,  $X^0 = 5\%$ ,  $X_n = 6\%$

$T_1, T_2$  : 100 MVA, 11KV/220 KV,  $X_{Leak} = 9\%$

$L_1, L_2$  :  $X^+ = X^- = 10\%$ ,  $X^0 = 5\%$ , on a base of 100 MVA

$G_1$  is connected with bus no.1

$G_2$  is connected with bus no.4

$T_1$  is connected between bus no.1 and bus no.2

$T_2$  is connected between bus no.3 and bus no.4

$L_1, L_2$  connected between bus no.2 and bus no.3

Assume phase at phase 'A' in bus no.4



## **RESULT**

Fault analysis of the given power system using Mi - Power software package is carried out and the results are presented.



## COMPUTATION OF TRANSMISSION LINE PARAMETERS

### EXERCISE : 6

#### AIM

To calculate the inductance and capacitance of a given single circuit configuration of a given transmission line through Mi – Power software package.

#### THEORY

##### (a). Calculation of Inductance and Capacitance

##### 1). Inductance of 3 phase single circuit symmetrical configuration

If the three conductors A, B, C are placed symmetrically at the corners of an equivalent triangle of side d, then  $d_1 = d_2 = d_3 = d$ . Under such condition the flux linkage with conductor A become

$$\begin{aligned}\varphi_A &= \frac{\mu_0}{2\pi} \left[ \left( \frac{1}{4} - \log e^r \right) I_A - I_B \log e^d - I_C \log e^d \right] \\ &= \frac{\mu_0}{2\pi} \left[ \left( \frac{1}{4} - \log e^r \right) I_A - (I_B + I_C) \log e^d \right] \\ &= \frac{\mu_0}{2\pi} \left[ \left( \frac{1}{4} - \log e^r \right) I_A + I_A \log e^d \right] \\ &= \frac{\mu_0 I_A}{2\pi} \left[ \left( \frac{1}{4} - \log e^r \right) + \log e^d \right] \\ &= \frac{\mu_0 I_A}{2\pi} \left[ \frac{1}{4} + \log e^d - \log e^r \right]\end{aligned}$$

$$\varphi_A = \frac{\mu_0 I_A}{2\pi} \left[ \frac{1}{4} + \log e^{d/r} \right] \text{ weber - turns/m}$$

Inductance of conductor A

$$\begin{aligned}L_A &= \frac{\varphi_A}{I_A} \text{ H/m} \\ &= \frac{\mu_0}{2\pi} \left[ \frac{1}{4} + \log e^{d/r} \right] \\ &= \frac{4\pi \times 10^{-7}}{2\pi} \left[ \frac{1}{4} + \log e^{d/r} \right]\end{aligned}$$

$$L_A = 10^{-7} [0.5 + 2 \log e^{d/r}] \text{ H/m}$$

##### 2) Capacitance of 3 phase single circuit symmetrical spacing configuration

The overall potential difference between conductor A and infinite neutral plane is

$$\begin{aligned}
 V_A &= \int_r^\infty \frac{Q_A}{2\pi x \epsilon_0} dx + \int_d^\infty \frac{Q_B}{2\pi x \epsilon_0} dx + \int_d^\infty \frac{Q_C}{2\pi x \epsilon_0} dx \\
 &= \frac{1}{2\pi \epsilon_0} (Q_A \log e^{1/r} + Q_B \log e^{1/d} + Q_C \log e^{1/d}) \\
 &= \frac{1}{2\pi \epsilon_0} ((Q_A \log e^{1/r} + (Q_B + Q_C) \log e^{1/d})
 \end{aligned}$$

Assume balanced supply  $Q_A = Q_B = Q_C = 0$

$$Q_B + Q_C = -Q_A$$

$$\begin{aligned}
 &= \frac{1}{2\pi \epsilon_0} (Q_A \log e^{1/r} - Q_A \log e^{1/d}) \\
 &= \frac{Q_A}{2\pi \epsilon_0} (\log e^{1/r} - \log e^{1/d})
 \end{aligned}$$

$$V_A = \frac{Q_A}{2\pi \epsilon_0} (\log e^{d/r})$$

Capacitance of a conductor A with respect to neutral

$$\begin{aligned}
 C_A &= \frac{Q_A}{V_A} \\
 C_A &= \frac{2\pi \epsilon_0}{\log e^{d/r}} F/m
 \end{aligned}$$

**DATA:**

**(i) Symmetrical Spacing**

1. Diameter of the conductor = 0.125 m
2. Spacing between conductor = 2 m
3. GMR (Inductance) = 0.00486 m
4. GMR (Capacitance) = 0.00625 m

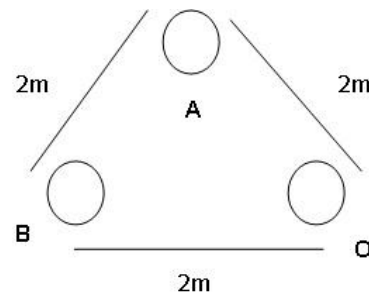

**(ii) Asymmetrical Spacing**

1. Diameter of the conductor = 1.5 cm
2. GMR = 0.00386 cm

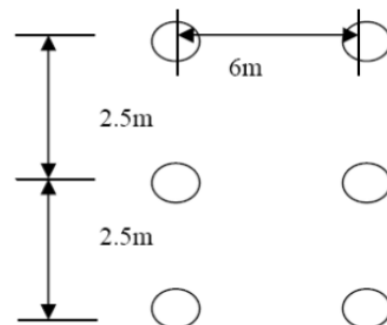

**(iii) Bundled Conductor**

1. Diameter of the conductor = 1.427 inch
2. Spacing between conductor = 18 inch
3. GMR = 0.564 inch

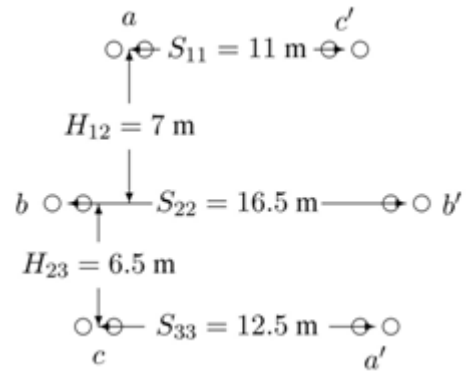

## **RESULT**

The Inductance and capacitance of a given transmission determined using Mi - Power software package

## MODELING OF TRANSMISSION LINE

### EXERCISE : 7

#### AIM:

To determine the voltage and current of receiving end of a given transmission line through Mi – Power software package.

#### THEORY:

The line models are classified by their length. These classifications are

- Short line approximation for lines that are less than 80 km long.
- Medium line approximation for lines whose lengths are between 80 km to 250 km.
- Long line model for lines that are longer than 250 km.

These models will be discussed in this chapter. However before that let us introduce the ABCD parameters that are used for relating the sending end voltage and current to the receiving end voltage and currents.

Consider the power system shown in Fig. 2.1. In this the sending and receiving end voltages are denoted by  $(\vec{V}_S)$  and  $(\vec{V}_R)$  respectively. Also the currents  $(\vec{I}_S)$  and  $(\vec{I}_R)$  are entering and leaving the network respectively.

$$\vec{V}_S = A \vec{V}_R + B \vec{I}_R \quad (1)$$

$$\vec{I}_S = C \vec{V}_R + D \vec{I}_R \quad (2)$$

From (2) we see that where

$$A = \frac{V_S}{V_R} \text{ at } (I_R = 0) \quad (3)$$

This implies that A is the ratio of sending end voltage to the open circuit receiving end voltage. This quantity is dimension less. Similarly,

$$B = \frac{V_S}{I_R} \text{ at } (V_R = 0) \text{ ohm} \quad (4)$$

i.e., B, given in Ohm, is the ratio of sending end voltage and short circuit receiving end current. In a similar way we can also define

$$C = \frac{I_S}{V_R} \text{ at } (I_R = 0) \text{ mho} \quad (5)$$

$$D = \frac{I_S}{I_R} \text{ at } (V_R = 0) \quad (6)$$

The parameter D is dimension less.

### Nominal- $\pi$ Representation

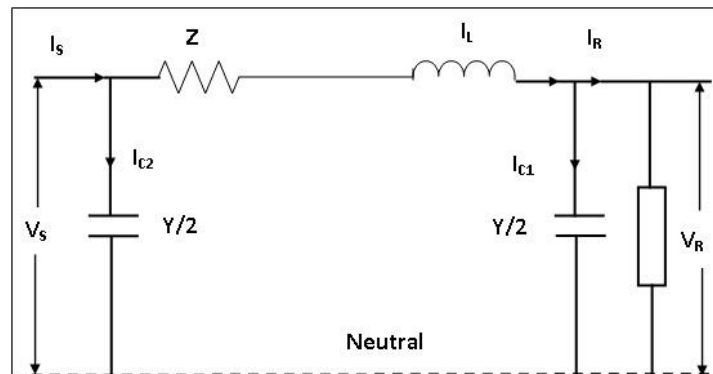

**Fig. 1 Short transmission line representation.**

In this representation the lumped series impedance is placed in the middle while the shunt admittance is divided into two equal parts and placed at the two ends. The nominal- $\pi$  representation is shown in Fig. 1. This representation is used for load flow studies, as we shall see later. Also a long transmission line can be modeled as an equivalent  $\pi$ -network for load flow studies.

Let us define three currents  $I_1$ ,  $I_2$  and  $I_3$  as indicated in Fig. Applying KCL at nodes M and N we get

$$\begin{aligned} I_S &= I_1 + I_2 = I_1 + I_3 + I_R \\ &= \frac{Y}{2} V_S + \frac{Y}{2} V_S + I_R \end{aligned} \quad (7)$$

Again

$$\begin{aligned} V_S &= Z I_2 + V_R \\ &= Z \left( V_R \frac{Y}{2} \right) + V_R \\ &= \left( \frac{YZ}{2} + 1 \right) V_R + Z I_R \end{aligned} \quad (8)$$

Substituting (7) in (8) we get

$$\begin{aligned}
 I_S &= \frac{Y}{2} \left[ \left( \frac{YZ}{2} + 1 \right) V_{R+} Z I_R \right] + \frac{Y}{2} V_R + I_R \\
 &= Y \left( \frac{YZ}{4} + 1 \right) V_R + Y \left( \frac{YZ}{2} + 1 \right) I_R
 \end{aligned} \tag{9}$$

Therefore from (8) and (9) we get the following ABCD parameters of the nominal- $\pi$  representation

$$A = D = \left( \frac{YZ}{2} + 1 \right)$$

$$B = Z \text{ ohm}$$

$$C = \left( \frac{YZ}{4} + 1 \right) \text{mho}$$

The constants A, B, C and D are generally complex numbers.

The constants A and D are dimensionless where as the dimensions of B and C are ohm and mho respectively.

For a given transmission line

$$A = D$$

For a given transmission line

$$AD - BC = 1$$

**DATA:**

Transmission line length	= 100 Km
Resistance of transmission line	= 0.124 $\Omega$ /Km
Inductance of transmission line	= 0.497 $\Omega$ /Km
Suspectance	= 3.3 x 10 <sup>-6</sup> mho/Km
Transmission line length	= 220 KV
Real power load/ demand	= 40 MW
Reactive power demand	= 19.37 MVAR

## RESULT

The ABCD parameters of a given transmission determined using Mi - Power software package and the results are presented.



## LOAD FREQUENCY CONTROL OF SINGLE AREA SYSTEM

### EXERCISE: 8

#### AIM:

To develop a single area load frequency control through Mi-power software package.

#### THEORY:

The real power in a power system is being controlled by controlling the driving torques of the individual turbines of the system. The speed governor is the main primary tool for the load frequency control.

#### Fly ball speed governor

It is purely mechanical speed sensitive device coupled directly to the hydraulic amplifier which adjust the control valve opening via for the fine linkage mechanism.

As the load increases speed of the turbine decreases, and the speed changer gives raise command, so the fly balls move outwards and the point B moves downwards and the reverse happens with the increased speed.

#### Speed Changer

It makes it possible to restore the frequency to the initial (nominal) value after the operation of the speed governor which has steady state.

characteristics corresponds to an increase  $\Delta P_C$  in the reference power setting.

#### Hydraulic Amplifier

It consists of pilot valve and main piston with this arrangement, a low power pilot valve movement is converted into high level movement of the oil, servomotor piston. The input to the amplifier is the position  $X_D$  of the pilot valve. The output is the position  $X_E$  of the main piston. Hydraulic amplification is necessary so that steam valve or gate could be operated against high pressure steam.

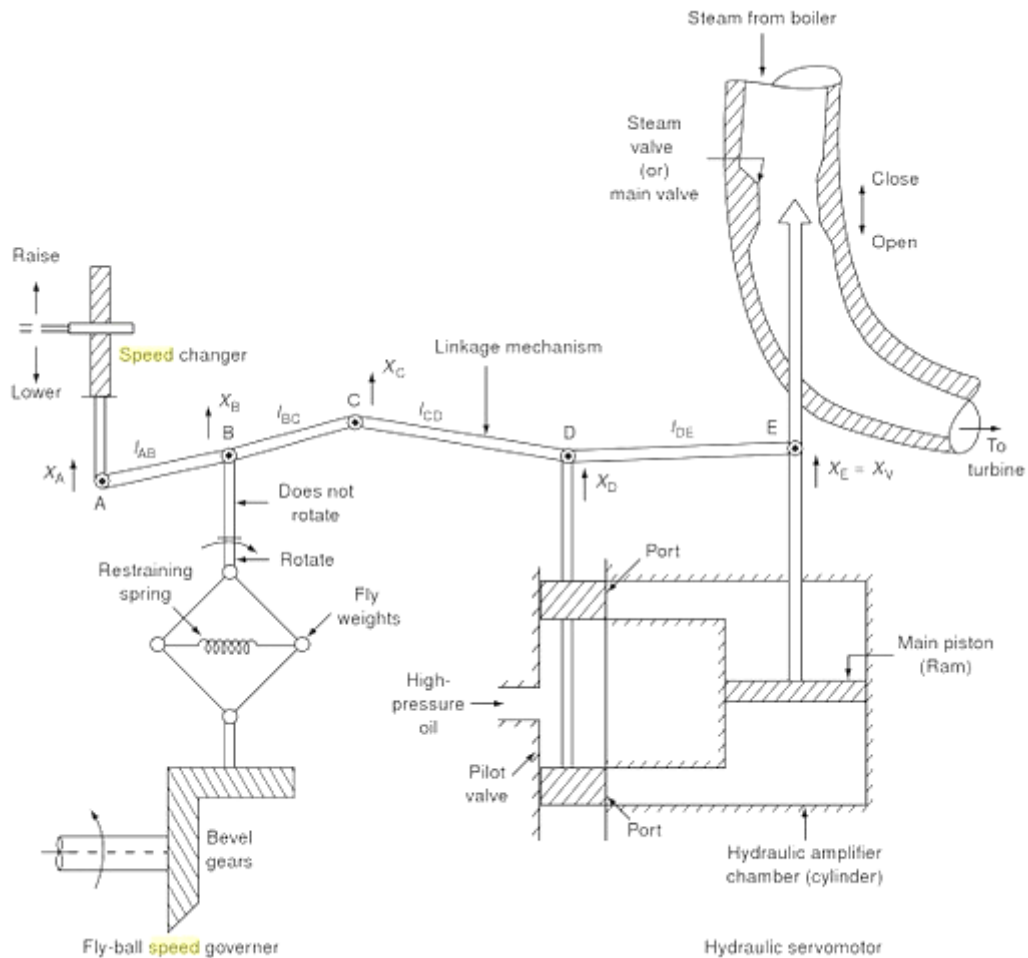

### Linkage Mechanism

ABC is rigid link pivoted at B and ODE is another rigid link pivoted at D. The functions of link mechanism is to control the steam valve or gate. We get feedback from the movement of the steam valve via link CD.

### Working

As load increases the speed of the turbine decreases, the speed changer gives raise command and the fly ball move outwards and point B moves downwards and D moves upwards and high pressure oil enters in to the upper pilot valve and presses the main piston downwards and opens the valve or gate i.e increases the flow of steam to the turbine.

### MODEL OF SPEED GOVERNING MECHANISM:

We shall develop the mathematical model based on small deviations around a nominal steady state. Consider the steam is operating under steady state and is delivering power  $P_G^0$  from the generator at nominal frequency  $f^0$ .

Let  $X_S^0$  be the steam valve setting. Let us assume that raise command  $\Delta P_C$ , to the speed changer, the point A moved downwards, by a small amount  $\Delta X_A$  which cause the turbine power output to change,

$$\Delta X_A = K_C \Delta P_C$$

Let us assume positive direction for downward movement and negative direction for upward movement.

**Movement of C:**

- (i)  $\Delta X_A$  contributes  $\left(\frac{-l_2}{l_1}\right) \Delta X_A = -K_1 \Delta X_A = -K_1 K_C \Delta P_C$
- (ii) Increase in frequency  $\Delta f$  cause the fly balls to move outwards so that b moves downwards by a proportional amount  $K_2 \Delta f$ .

$$\Delta X_C = -K_1 K_C \Delta P_C + K_2 \Delta f \tag{1}$$

**Movement of D:**

It is contributed by  $\Delta X_C$  and  $\Delta X_T$ . The movement of  $\Delta X_D$  is the amount by which the pilot valve open, thereby moving the main piston and opening the steam valve by  $\Delta X_E$ .

$$\begin{aligned} \Delta X_D &= \left(\frac{l_1}{l_3+l_4}\right) \Delta X_C + \left(\frac{l_3}{l_3+l_4}\right) \Delta X_E \\ &= K_3 \Delta X_C + K_4 \Delta X_E \end{aligned} \tag{2}$$

**Movement of  $\Delta X_E$  :**

The volume of oil admitted to the cylinder is thus proportional to the line integral of  $\Delta X_D$ .

$$\Delta X_E = K_5 \int_0^t (-\Delta X_D) dt \tag{3}$$

Taking Laplace transform of equ (1), (2) and (3)

$$\Delta X_C(S) = -K_1 K_C \Delta P_C(S) + K_2 \Delta F(S) \tag{4}$$

$$\Delta X_D(S) = K_3 \Delta X_C(S) + K_4 \Delta X_E(S) \tag{5}$$

$$\Delta X_E(S) = \frac{-K_5}{S} \Delta X_D(S) \tag{6}$$

Substituting equation (5) in (6) we get,

$$\Delta X_E(S) = \frac{-K_5}{S}(K_3 \Delta X_C(S) + K_4 \Delta X_E(S))$$

$$\Delta X_E(S) \left(1 + \frac{K_4 K_5}{S}\right) = \frac{-K_5 K_3}{S} \Delta X_C(S) \quad (7)$$

Substituting equ (4) in (7) we get,

$$\Delta X_E(S) \left(1 + \frac{K_4 K_5}{S}\right) = \frac{-K_5 K_3}{S} (-K_1 K_C \Delta P_C(S) + K_2 \Delta F(S))$$

$$\Delta X_E(S) \left(\frac{S + K_4 K_5}{S}\right) = \left(\frac{K_5 K_3 K_1 K_C \Delta P_C(S) - K_2 K_5 K_3 \Delta F(S)}{S}\right)$$

$$\Delta X_E(S) = \left(\frac{K_5 K_3 K_1 K_C \left(\Delta P_C(S) - \frac{K_2}{K_1 K_C} \Delta F(S)\right)}{K_4 K_5 \left(1 + \frac{S}{K_4 K_5}\right)}\right)$$

$$\Delta X_E(S) = \frac{K_3 K_1 K_C}{K_4} \left(\frac{\Delta P_C(S) - \frac{K_2}{K_1 K_C} \Delta F(S)}{1 + \frac{S}{K_4 K_5}}\right)$$

This equation can be written as,

$$\Delta X_E(S) = \left[ \Delta P_C(S) - \frac{1}{R} \Delta F(S) \cdot \frac{K_G}{1 + ST_G} \right] \quad (8)$$

Where,

$$R_1 = \frac{K_1 K_C}{K_2} \text{ – speed regulation of the governor in Hz/MW}$$

$$K_G = \frac{K_3 K_1 K_C}{K_4} \text{ – gain of the governor}$$

$$T_G = \frac{1}{K_4 K_5} \text{ – time constant of speed governor}$$

- Value of  $T_G < 100$  msec

The output of a generating unit at a given system frequency can be varied only by changing its “ Load reference or control point” which is integrated with the speed governing mechanism.

### Turbine model

We are interested in the increased power generation  $\Delta P_G$  due to the increased steam valve opening. There is an incremental increase in turbine power  $\Delta P_T$  due to the change in valve position  $\Delta X_E$ , which will result in an increase in generator power  $\Delta P_G$ . If the generator incremental loss is neglected then

$$\Delta P_T = \Delta P_G$$

The figure for non-reheat turbine is shown in fig.

$T_t$  = Time constant of turbine

$K_t$  = Gain constant

$\Delta P_v$  = Per unit change in valve position from nominal value

### Generator Load Model:

To develop the mathematical model of an isolated generator, which is only supplying local load and is not supplying power to another area. Suppose there is a real load change of  $\Delta P_D$ . The net surplus power ( $\Delta P_G - \Delta P_D$ ) will be absorbed by the system in two ways.

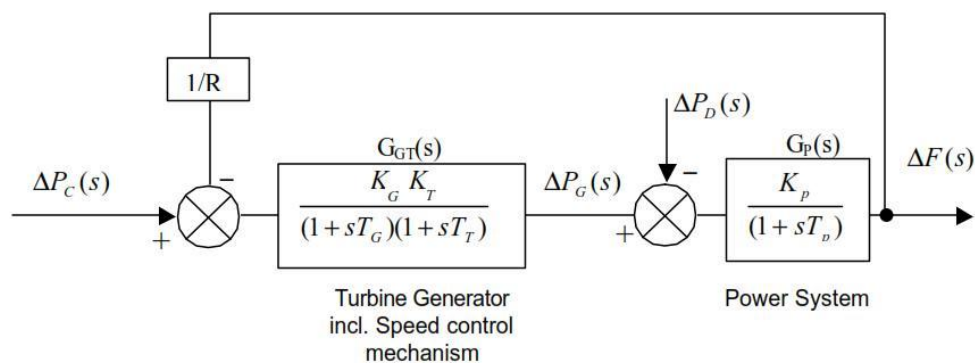

1. By increasing the kinetic energy stored in the rotor at the rate  $\frac{d}{dt} (W_{KE})$

$$W_{KE}^0 = H.P_r \text{ KW seconds}$$

$$W_{KE}^0 = \frac{J\omega_0^2}{2} = W_{KE}^0 \propto f_0^2 \tag{9}$$

$$W_{KE} \propto (f_0 + \Delta f)^2 \tag{10}$$

Dividing equ (10) by (9) we get

$$\begin{aligned} W_{KE} &= W_{KE}^0 \left( \frac{f_0 + \Delta f}{f_0} \right)^2 = W_{KE}^0 \left( 1 + \frac{\Delta f}{f_0} \right)^2 \\ &= W_{KE}^0 \left( 1 + \frac{2\Delta f}{f_0} + \frac{\Delta f^2}{f_0^2} \right) \\ &= W_{KE}^0 \left( 1 + \frac{2\Delta f}{f_0} \right) \text{ neglect second order term.} \end{aligned}$$

Substituting  $W_{KE}^0$ ,

$$W_{KE} = H.P_r \left( 1 + \frac{2\Delta f}{f_0} \right) \quad (11)$$

Rate of change of kinetic energy,

$$\frac{dW_{KE}}{dt} = \frac{2HP_r}{f_0} \frac{d}{dt} \Delta f \quad (12)$$

2. As the frequency changes, the motor load changes being sensitive to speed

Rate of change of load with respect to frequency  $\frac{\partial P_D}{\partial f} = B$

Where,

$B$  = damping co-efficient in MW/Hz.

Values of damping co-efficient is positive for motor load.

$$\Delta P_G - \Delta P_D = B\Delta f$$

Writing power balance equation,

$$\Delta P_G - \Delta P_D = \frac{2HP_r}{f_0} \frac{d}{dt} (\Delta f) + B\Delta f$$

Dividing by  $P_r$ ,

$$\Delta P_{G_{p.u}} - \Delta P_{D_{p.u}} = \frac{2H}{f_0} \frac{d}{dt} (\Delta f) + B_{p.u} \Delta f$$

Taking laplace transform,

$$\Delta P_G(S) - \Delta P_D(S) = \Delta F(S) \left( \frac{2H(S)}{f_0} + B \right)$$

$$\Delta F(S) = \frac{\Delta P_G(S) - \Delta P_D(S)}{B \left( 1 + \frac{2H(S)}{f_0} \right)}$$

$$\Delta F(S) = \Delta P_G(S) - \Delta P_D(S) \left( \frac{K_P}{1 + sT_P} \right)$$

Where,

$$K_P = \frac{1}{B} = \text{Power system gain}$$

$$T_P = \frac{2H}{f_0} = \text{Power system time constant}$$

Combining the governor model, turbine model and generator model, we get the complete block diagram representation of LFC of an isolated power which is shown in fig.

**DATA:**

Rated capacity of the area	= 2000 MVA
Normal operating load	= 1000 MW
Nominal frequency	= 60 Hz
Inertia Constant (H)	= 5.0
Governor droop for all regulating generators	= 4 %
Governor time constant	= 0.05 sec
Turbine time constant	= 0.30 sec
Sudden rise in load value	= 20 MW
Rate of change of load ( $D_{PL}$ )	= 1.0
$D_{PF}$	= 1.0
$D_T$	= 0.01
$T_{max}$	= 20.0

**RESULT:**

Thus for given single area system, load frequency control dynamics analysis was carried out using Mi-Power software package and LFC pattern were presented.



## LOAD FREQUENCY CONTROL OF TWO AREA SYSTEM

### EXERCISE 8

#### AIM:

To develop a two area load frequency control through Mi-power software package.

#### THEORY

An extended power system can be divided into a number of load frequency control areas interconnected by means of tie lines. Without loss of generality, we shall consider a two area case connected by a single tie line as illustrated in fig.

The control objective now is to regulate the frequency of each area and to regulate the tie line power as per inter area power contracts. As in the case of frequency proportional plus integral controller will be installed so as to give zero steady state error in the tie line flow as compare to the contracted power.

It is assumed that each control area can be represented by equivalent turbine generator and governor system. Symbols used with suffix '1' refers to area '1'.

In an isolated control area case, the incremental power ( $\Delta P_G - \Delta P_D$ ) was accounted for the rate of increase in area load, caused by increase in frequency. Since, a tie line transports power in or out of an area, this fact must be accounted for in the incremental power balance equation of each area.

Power transported out of area 1 is given by,

$$P_{tie,1} = \frac{|V_1||V_2|}{X_{12}} \sin(\delta_1^0 - \delta_2^0) = P_{max} \sin(\delta_1^0 - \delta_2^0)$$

Where,

$\delta_1^0, \delta_2^0$  = Power angle of equivalent machines of the two area

For incremental changes in  $\delta_1$  and  $\delta_2$  the incremental tie line can be expressed as,

Apply partial differentiation with respect to ' $\delta$ '

$$\frac{\partial P_{tie,1}}{\partial \delta_{12}} = \frac{|V_1||V_2|}{X_{12}} \cos(\delta_1^0 - \delta_2^0) (\Delta \delta_1 - \Delta \delta_2)$$

$$\Delta P_{tie,1p.u} = \frac{|V_1||V_2|}{X_{12}P_{r1}} \cos(\delta_1^0 - \delta_2^0) (\Delta\delta_1 - \Delta\delta_2)$$

$$\Delta P_{tie,1p.u} = T_{12}(\Delta\delta_1 - \Delta\delta_2)$$

Where

$$T_{12} = \frac{|V_1||V_2|}{X_{12}P_{r1}} \cos(\delta_1^0 - \delta_2^0)$$

Synchronizing power co-efficient or electric or dielectric (i.e) slope of the power angle curve at the initial stiffness operating angle  $\delta_{12}^0$ .

$T_{12}$  is defined as the differential power increase obtained per differential power angle increase obtained per differential power angle increase.

Since incremental frequency  $\Delta f$  is related to the phase angle of deviation,

$$\omega = 2\pi f$$

$$f = \frac{\omega}{2\pi}$$

$$= \frac{1}{2\pi} \frac{d\delta}{dt}$$

$$(i.e) \quad \Delta f = \frac{1}{2\pi} \frac{d}{dt} (\Delta\delta)$$

$$\Delta\delta = 2\pi \int \Delta f \cdot dt$$

We can equ  $T_{12}$  as,

$$\Delta P_{tie,1} = 2\pi T_{12} [\int \Delta f_1 \cdot dt - \int \Delta f_2 \cdot dt]$$

Where  $\Delta f_1$  and  $\Delta f_2$  are incremental frequency changer of areas '1' and '2' respectively.

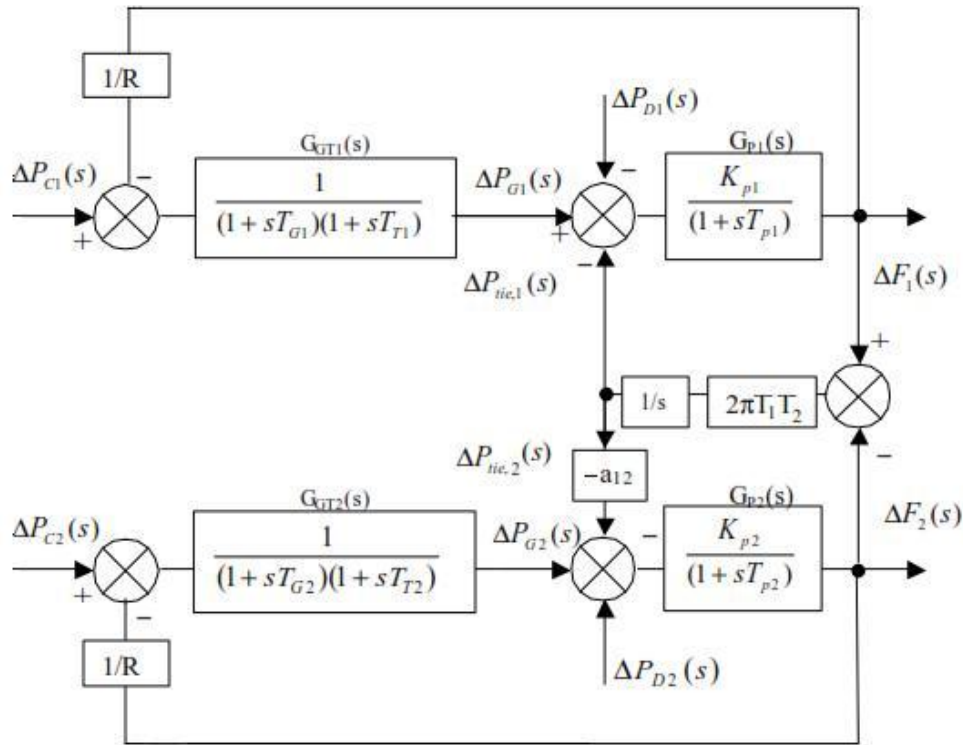

Similarly,

$$\Delta P_{tie,1} = 2\pi T_{21} [\int \Delta f_2 \cdot dt - \int \Delta f_1 \cdot dt]$$

$$T_{12} = \frac{|V_2||V_1|}{X_{12}P_{r2}} \cos(\delta_2^0 - \delta_1^0) \cdot \frac{P_{r1}}{P_{r1}}$$

$$P_{21} = \left(\frac{P_{r1}}{P_{r2}}\right) T_{12} = a_{12}T_{12}$$

Where,

$$a_{12} = \left(\frac{P_{r1}}{P_{r2}}\right)$$

The incremental power balance equation for area '1' can be written as,

$$\Delta P_{G1} - \Delta P_{D1} = \frac{2H}{f_0} \frac{d}{dt} (\Delta f_1) + B_1 \Delta f_1 + \Delta P_{tie,1}$$

Taking LT on equation of above and rearranging we get,

$$\Delta P_{G1}(S) - \Delta P_{D1}(S) - \Delta P_{tie,1}(S) = \Delta f_1(S) \left[ B_1 + \frac{2H_1 S}{f_0} \right]$$

$$\Delta f_1(S) = \frac{\Delta P_{G_1}(S) - \Delta P_{D_1}(S) - \Delta P_{tie,1}(S)}{B_1 + \frac{2H_1 S}{f_0}}$$

$$= [\Delta P_{G_1}(S) - \Delta P_{D_1}(S) - \Delta P_{tie,1}(S)] \frac{1/B_1}{1 + \frac{2H_1 S}{f_0 B_1}}$$

$$\Delta f_1(S) = [\Delta P_{G_1}(S) - \Delta P_{D_1}(S) - \Delta P_{tie,1}(S)] \frac{K_P S_1}{1 + ST_P S_1}$$

Where,

$$K_P S_1 = \frac{1}{B_1} \quad = \text{Power system gain for area '1'}$$

$$T_P S_1 = \frac{2H_1}{f_0 B_1} \quad = \text{Power system time constant for area '1'}$$

Taking LP transform of equation,

$$\Delta P_{tie,1}(S) = \frac{2\pi T_{12}}{S} [\Delta f_1(S) - \Delta f_2(S)]$$

For the control area '2',

$$\Delta P_{tie,2}(S) = \frac{2\pi T_{21}}{S} [\Delta f_2(S) - \Delta f_1(S)]$$

$$\Delta P_{tie,2}(S) = \frac{-2\pi a_{12} T_{21}}{S} [\Delta f_1(S) - \Delta f_2(S)]$$

**DATA:**

Number of areas	= 2
Rated capacity of the area	= 2000 MVA
Normal operating load	= 1000 MW
Nominal frequency	= 60 Hz
Inertia Constant (H)	= 5.0
Governor droop for all regulating generators	= 4 %
Governor time constant	= 0.08 sec
Turbine time constant	= 0.30 sec
Sudden rise in load value ( $D_{PD}$ )	= 0 MW (for Area 1); 20 MW (for Area 2);
Rate of change of load ( $D_{PL}$ )	= 1.0
$D_{PF}$	= 1.0
$D_T$	= 0.01
$T_{max}$	= 20.0

**RESULT:**

Thus for given two area system, load frequency control dynamic analysis was carried out using Mi-Power software package and LFC pattern were presented.

## **TRANSIENT STABILITY ANALYSIS OF MULTI MACHINE POWER SYSTEM**

### **EXERCISE 10**

#### **AIM**

To study out the transient analysis of a 3 bus 60 Hz Power System through Mi – Power software package.

#### **THEORY:**

Transient stability is the ability of the power system to maintain synchronism when subjected to a severe transient disturbance. The result in system response involves large excursions of generator rotor angles and is influenced by the non – linear power angle relationship. Stability depends on both the initial operating states of the system and the severity of the disturbance, usually the system is altered so that the post disturbance study state operation differs from that prior to the disturbance.

Disturbances of widely varying degrees of severity and probability of occurrence can occur on the system. The system is however designed and operated so as to be stable for a selected set of contingencies usually considered are short circuit of different types such as phase to ground or three phase fault. They are usually assumed to occur on transmission lines but occasionally bus or transformer faults are also considered the fault is assumed to be cleared by the opening of appropriate circuit breakers to isolate the faulted element. In some cases high speed re-closure may be assumed.

#### **MULTI-MACHINE STABILITY:**

A multi-machine system would be extremely complex to analyze if individual machine behaviors are to be considered however many of the multi – machine system encountered in industrial practice contain only synchronous machines which are similar in

characteristics closely coupled electrically and connected to a high capacity utility system. Under most types of disturbances the machines remain synchronous to one another through they can all loss synchronism with the utility hence the  $\delta$  values of all values will be same. Therefore the individual swing equations can be combined as in case of two coherent machines problem. Hence only one swing equation to be solved for stability studies assuming coherent machines. However for detailed analysis it is better to represent all the machines individually and conduct the studies. Normally in this study the classical model, the transient model and the sub – transient model are used.

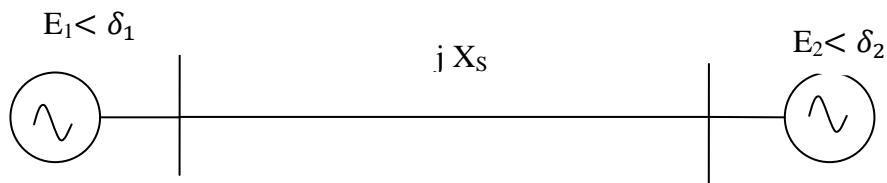
**Calculation for Power angle Equation:**

Consider a two bus system shown in fig, connected by equivalent reactance  $X_S$ .

Therefore,

$$\delta = \delta_1 - \delta_2$$

$$X_S = \text{Reactance}$$

Therefore, the power transfer from node 1 to node 2 is given by

$$P = \frac{E_1 E_2}{X} \sin \delta$$

$$= P_{max} \sin \delta$$

$E_1$  = Magnitude voltage of bus 1.

$E_2$  = Magnitude voltage of bus 2.



**Transient Stability Study Info:**

1. 3 $\phi$  to ground fault at bus 5.
2. Disturbance starting time 0 sec.
3. Disturbance clearance time 0.083 sec.

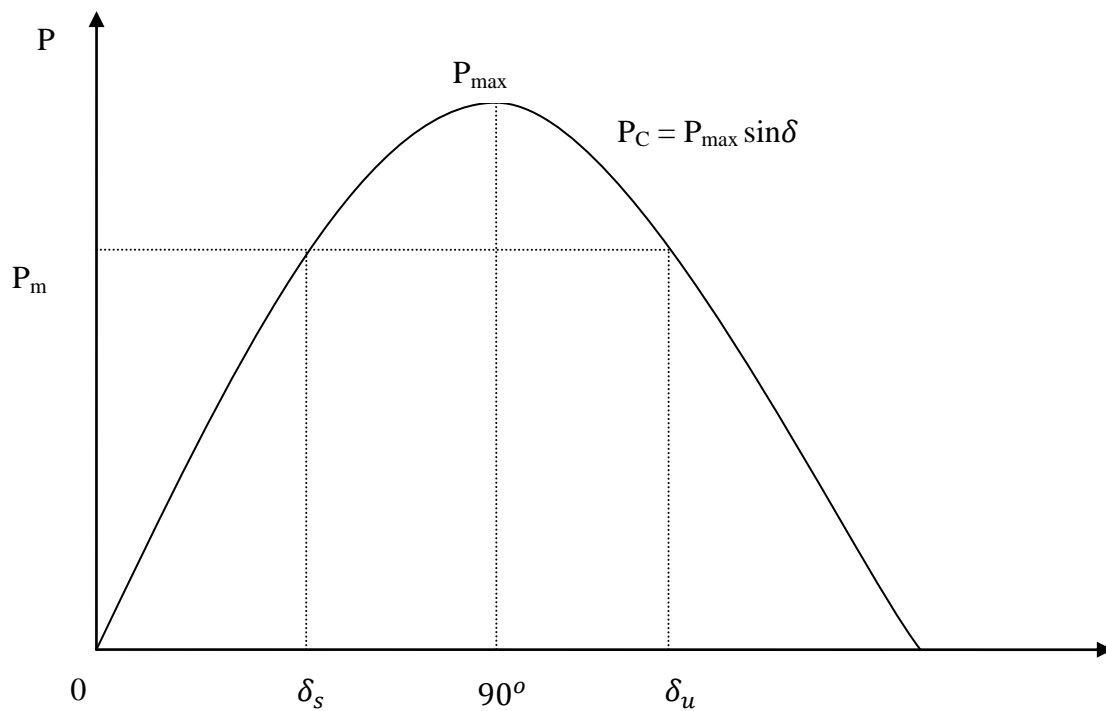

In this power angle equation we can consider two operating regions.

**Stable Regions:**

- a. As,  $\delta_s$ ;  $P_m = P_e$  net accelerating torque = 0
- b. Let electrical power  $P_e$  decrease slightly then,

$$\frac{H}{\pi f} \frac{d^2 \delta}{dt^2} = P_m - P_e \text{ is positive}$$

- c.  $\delta_s$  is stable operating point.

**Unstable region**

- a. As,  $\delta_u$

- b.  $\frac{H}{\pi f} \frac{d^2\delta}{dt^2} = P_m - P_e$  is negative.
- c.  $\delta_u$  is unstable operating point.

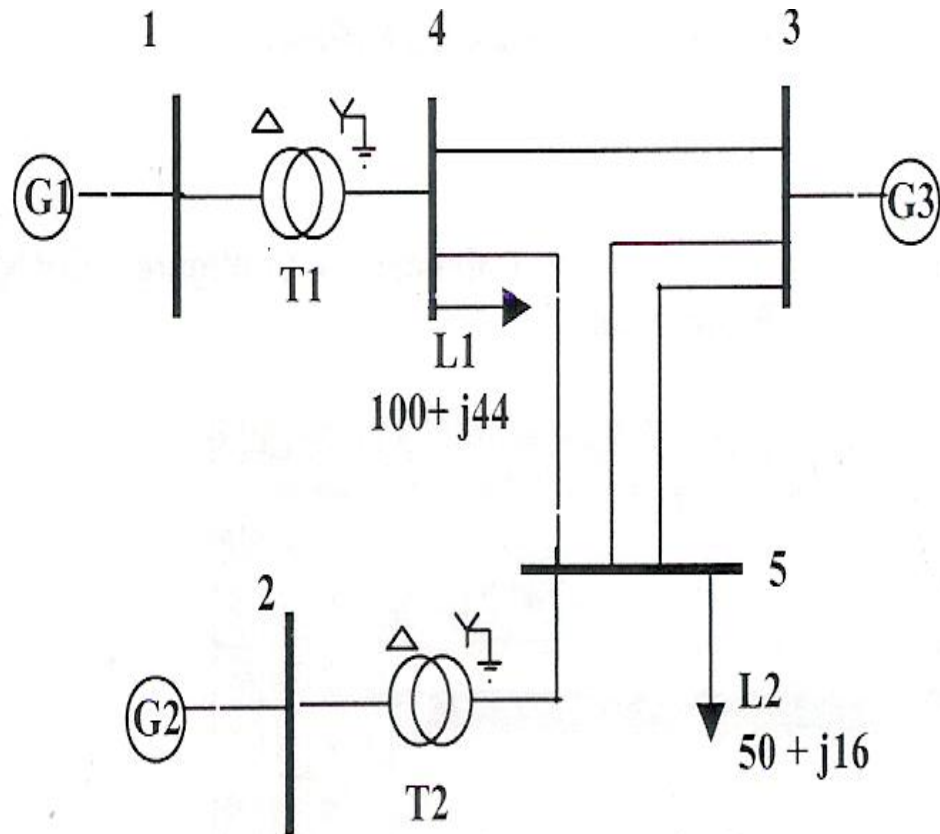

Values given are on 100 MVA Base. Frequency = 60 Hz

**Bus Data:**

Bus No.	Nominal Voltage (KV)
1	16.5
2	18
3	230
4	230
5	230.

**Transformer Reactance:**

Transformer	Reactance
T1	0.0576
T2	0.0625

**Line Data:**

Line No.	SB	EB	R + jX	B/2
1	3	4	0.010 + j0.085	0.088
2	3	5	0.017 + j0.092	0.079
3	3	5	0.32 + j0.161	0.153
4	4	5	0.39 + j0.17	0.179

**Generator data:**

Generator	1	2	3
Rated MVA	247.5	192	128
KV	16.5	18	230
Power Factor	0.85	0.85	--
Speed	1800 rpm	3600 rpm	3600 rpm
$X_d$	0.1460	0.8958	1.3125
$X_d'$	0.6080	0.1198	0.1813
$X_q$	0.0969	0.8645	1.2578
$X_q'$	0.0969	0.1969	0.25
$X_{leak}$	0.0336	0.0521	0.0742
Time Constant $T_{do}'$	8.96	6.0	5.89
$T_{qo}'$	0	0.5350	0.6
Stored Energy at Rated Speed	2364 MW - Sec	640 MW - Sec	301 MW - Sec

**Load data:**

Load	R + jX (MVA)
A	100+ j44
B	50+ j16

**RESULT:**

Thus the transient stability analysis of a 5 Bus – 3 machine system was analyzed using Mi –Power software package.

**SMALL SIGNAL STABILITY ANALYSIS OF SINGLE MACHINE INFINITE BUS SYSTEM**

**EXERCISE 11**

**AIM**

Analyze the small signal stability of a single machine infinite bus system through Mi-Power software package.

**THEORY:**

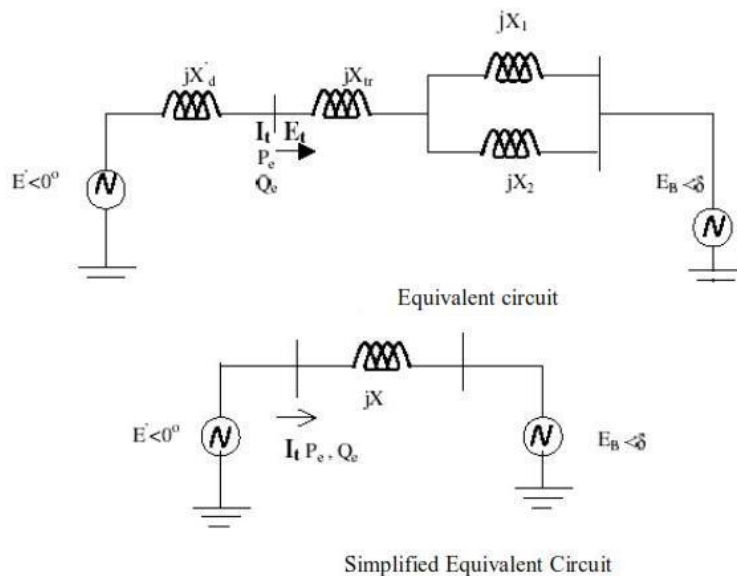

For the purpose of analysis fig (a) is reduced to fig (b) using thevenin's equivalent of the transmission network external to the machine and the adjacent transmission.

Because of the relative size of the system to which the machine is supplying power dynamics associated with the machine will cause virtually no change in the voltage and frequency of thevenin's voltage  $E_B$ . Such a source of constant voltage and constant frequency is referred to an infinite bus.

For any given system condition, the magnitude of infinite bus voltage  $E_B$  remains constant. However as the steady state condition change, the magnitude of  $E_B$  may change represent a changed generating condition of the external network.

We will analyze the small signal stability of the system with the synchronous machine represented by models of varying degree of detail. We will begin with the classical model and

gradually increase the model detail by accounting for the effects of the dynamics of the field, circuits and excitation system.

In each case we will develop the expressions for the elements of state matrix as explicit function of the system parameters. This will help make clear the effects of various factor associated with a synchronous machine on system stability. In addition to the state space representation and model analysis we will use the block diagram representation and torque angle relationship to analyze the system stability characteristics.

**CALCULATION:**

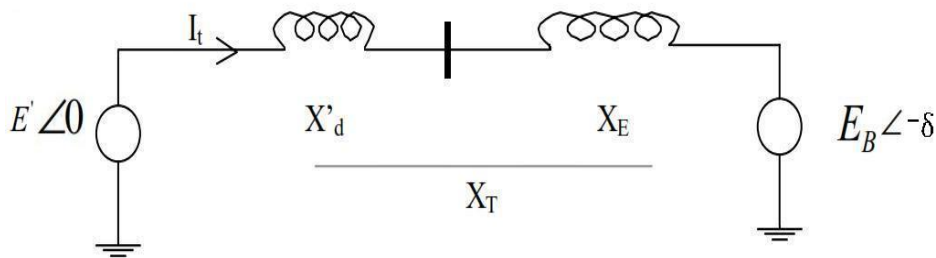

Figure: 6.5.1 Classical Model

Let  $E'$  = Voltage behind  $X'd$

$\delta$  = Angle by which  $E'$  leads the infinite bus voltage  $E_B$ .

With  $E'$  as reference phasor

$$I_t = \frac{E' \angle 0 - E_B \angle -\delta}{jX_T}$$

$$= \frac{E' \angle 0 - E_B (\cos\delta - j \sin\delta)}{jX_T}$$

The complex power behind  $X_d'$  is given by

$$S' = P + jQ' = E' I_t^*$$

$$= \frac{E' E_B \sin\delta}{X_T} + j \frac{E' (E' - E_B \cos\delta)}{X_T}$$

In p.u the air gap torque is equal to the air gap power

Here,

$$T_e = \frac{E'E_B}{X_T} \sin\delta$$

Linearizing about an initial operating condition represented by  $\delta = \delta_0$  yields

$$\Delta T_e = \frac{\partial T_e}{\partial \delta} \Delta\delta = \frac{E'E_B}{X_T} \cos\delta_0 (\Delta\delta)$$

The equation of motion in p.u are

$$P \Delta\omega_r = \frac{1}{2H} (T_m - T_e - K_D \Delta\omega_r)$$

$$P \delta = \omega_0 \Delta\omega_r$$

Also

$$P \Delta\omega_r = \frac{1}{2\pi} (\Delta T_m - K_S \Delta\delta - K_D \Delta\omega_r)$$

Where  $K_S$  is synchronizing torque co-efficient and is given by

$$K_S = \frac{E'E_B}{X_T} \cos\delta_0$$

Linearizing the (6) we get,

$$P \Delta\delta = \omega_0 \Delta\omega_r$$

Writing the (7) & (9) in vector matrix, we obtain

$$\frac{d}{dt} \begin{bmatrix} \Delta\omega_r \\ \Delta\delta \end{bmatrix} = \begin{bmatrix} -K_D & -K_S \\ \frac{2H}{\omega_0} & 0 \end{bmatrix} \begin{bmatrix} \Delta\omega_r \\ \Delta\delta \end{bmatrix} + \begin{bmatrix} 1 \\ \frac{1}{2H} \end{bmatrix} \Delta T_m$$

Where

$K_S$  = Synchronising torque co-efficient

$K_D$  = Damping torque co-efficient in p.u torque/p.u speed deviation

$H$  = Inertia constant in MW. S/MVA

$\Delta\omega_r$  = Speed deviation in p.u

$\Delta\delta$  = Rotor angle deviation in electrical radii

$\Delta$  = Laplace operator

$\omega$  = rated speed in electrical rad/s

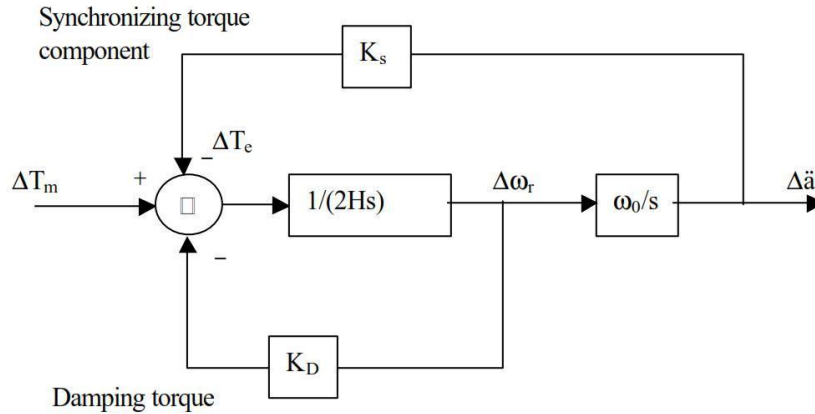

From the block diagram, we have

$$\begin{aligned} \Delta\delta &= \frac{\omega_0}{s} \left[ \frac{1}{2HS} (-K_S \Delta\delta - K_D \Delta\omega_r + \Delta T_m) \right] \\ &= \frac{\omega_0}{s} \left[ \frac{1}{2HS} \left( -K_S \Delta\delta - K_D S \frac{\Delta\delta}{\omega_0} + \Delta T_m \right) \right] \end{aligned}$$

Rearranging we get,

$$S^2(\Delta\delta) + \frac{K_D}{2H} S(\Delta\delta) + \frac{K_S}{2H} \omega_0(\Delta\delta) = \frac{\omega_0}{2H} \Delta T_m$$

Therefore the characteristic equation is given by

$$S^2 + \frac{K_D}{2H} S + \frac{K_S}{2H} \omega_0 = 0$$

This is of the general form

$$S^2 + 2 S \omega_n + \omega_n^2 = 0$$

Therefore the un-damped natural frequency is

$$\omega_n = \sqrt{\frac{K_S}{2H}} \omega_0 \text{ rad/sec}$$

and the damping ratio is



$$S = \frac{1}{2} \frac{K_D}{2H\omega_n}$$

**SINGLE LINE DIAGRAM:**

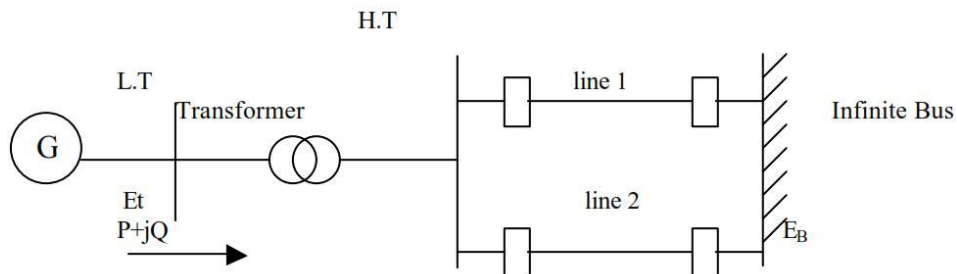

**DETAILED DIAGRAM:**

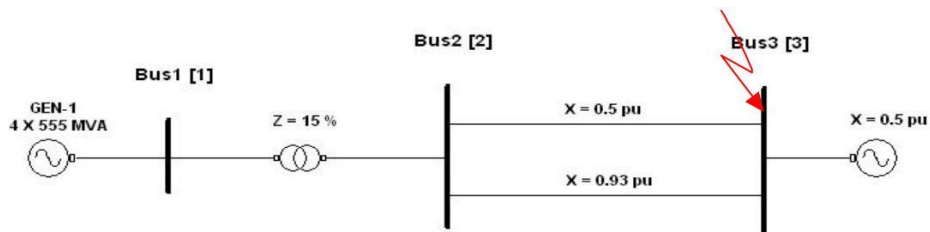

Note: All the values are in pu on 2220MVA, 24kV base

**DATA:**

**Generator:**

555 MVA x 4 Units

$$X_d' = 0.3 \text{ p.u}$$

$$H = 3.5 \text{ Mw-s/MVA}$$

$$\text{Voltage} = 24 \text{ KV, } 60 \text{ Hz}$$

**Transformer:**

$$\text{Voltage Ratio} = 24/220 \text{ KV}$$

$$\text{Reactance} = 0.15 \text{ p.u}$$

**Line:**

$$\text{Reactance of line 1} = 0.5 \text{ p.u}$$

$$\text{Reactance of line 2} = 0.93 \text{ p.u}$$

$$\text{Reactance of infinite bus} = 0.5 \text{ p.u}$$

**Fault:**

Three phase to ground fault at end of line 2 occur at  $t = 0$  sec;  
clearing at  $t = 0.07$  sec

$E_t = 1.0$  p.u;

PF = 0.9

Plant operating condition  $P = 0.9$  pu

**RESULT:**

Thus for a given single bus infinite system, small signal stability analysis was carried out using Mi-Power software package.

## ECONOMIC DISPATCH IN POWER SYSTEM

### EXERCISE 12

#### AIM:

To solve economic dispatch and unit commitment problem of a given power system using Mi – Power package.

#### THEORY:

#### ECONOMIC DISPATCH PROBLEM:

The purpose of economic dispatch (or) optimal dispatch is to reduce fuel costs for the power system. By economic load scheduling, we mean to find the generation of the different generators (or) plants, so that the total fuel cost is minimum and at the same time the total demand and losses at any instant must be met by total generation. The economic dispatch problem involves the solution of two different problems.

We know that  $F_T = F_1 + F_2 + \dots + F_N$

Equality Constraint:  $\sum_{i=1}^N P_{G_i} - P_D = 0$

Inequality Constraint:  $P_{G_{i,min}} \leq P_{G_i} \leq P_{G_{i,max}}$

The necessary condition, for the existence of a minimum cost operating condition is that the incremental cost rates of all the units will be equal to some undetermined value  $\lambda$

$$\frac{dF_i}{dP_{G_i}} = \lambda$$

The power balance equation is  $\sum_{i=1}^N P_{G_i} = P_D$ . There are two inequalities that must be satisfied for each of the units.

$$P_{G_{i,min}} \leq P_{G_i} \leq P_{G_{i,max}}$$

The necessary conditions may be expanded slightly as shown in the set of equation.

$$\frac{dF_i}{dP_{G_i}} = \lambda : \text{for } P_{G_{i,min}} \leq P_{G_i} \leq P_{G_{i,max}}$$

$$\frac{dF_i}{dP_{G_i}} \leq \lambda : P_{G_i} = P_{G_{i,min}}$$

$$\frac{dF_i}{dP_{G_i}} \geq \lambda : P_{G_i} = P_{G_{i,max}}$$

The net saving cost  $\Delta F_t = \Delta F_1 + \Delta F_2$

Where

$\Delta F_1$  = Increase in cost for unit 1.

$\Delta F_2$  = Increase in cost for unit 2.

$$\Delta F_i = \int \frac{dF_i}{dP_{G_i}} \cdot dP_{G_i}$$

The possible observation concerned to  $\Delta F_t$  are,

1. If  $\Delta F_t < 0$ , the fuel input to the system is decreased by increasing generation on source 1 and consequently, the initial generation schedule was not optimum.
2. If  $\Delta F_t > 0$ , the fuel input to the system is increased by increasing the generation of source 1 and in this case it would not be desirable to increase the output of source 1.

**Solution by  $\lambda$  - iteration method without loss**

**Step: 1** Assign initial trial value of  $\lambda$  or calculate  $\lambda$  using

$$\lambda = \frac{P_D + \sum_{i=1}^N \frac{b_i}{2a_i}}{\sum_{i=1}^N \frac{1}{2a_i}}$$

**Step: 2** Compute  $P_{G_i}$  corresponding to  $\lambda$  using equations

$$P_{G_i} = \alpha_i + \beta_i (\text{IC}) + \gamma_i (\text{IC})^2$$

$$P_{G_i} = \alpha_i + \beta_i \lambda + \gamma_i \lambda^2 \text{ (or)}$$

$$\gamma_{G_i} = \frac{\lambda - b_i}{2a_i}$$

**Step: 3** Compute  $\sum_{i=1}^N P_{G_i}$

**Step: 4** Check the power balance equation  $\sum_{i=1}^N P_{G_i} = P_D$

**Step: 5** If  $\sum_{i=1}^N P_{G_i} < P_D$

Assign  $\lambda = \lambda + \Delta\lambda$

If  $\sum_{i=1}^N P_{G_i} > P_D$

Assign  $\lambda = \lambda - \Delta\lambda$

Where  $\Delta\lambda = \frac{(\Delta P)}{\sum_{i=1}^N \frac{1}{2a_i}}$  ( $\Delta P$  – Change in demand)

### DATA

(i) Total Demand = 850MW

**Operating limits:**

$$150 \text{ MW} \leq P_1 \leq 600 \text{ MW}$$

$$100 \text{ MW} \leq P_2 \leq 400 \text{ MW}$$

$$50 \text{ MW} \leq P_3 \leq 200 \text{ MW}$$

**Production cost function in Rs / hr**

$$F_1 = 459 + 6.48 P_1 + 0.00128 P_1^2 \text{ Rs./Hr}$$

$$F_2 = 310 + 7.85 P_2 + 0.0019 P_2^2 \text{ Rs./Hr}$$

$$F_3 = 78 + 7.97 P_3 + 0.00482 P_3^2 \text{ Rs./Hr}$$

(ii) Total Demand = 150 MW

**Operating limits:**

$$10 \text{ MW} \leq P_1 \leq 100 \text{ MW}$$

$$10 \text{ MW} \leq P_2 \leq 100 \text{ MW}$$

**Production cost function in Rs / hr**

$$F_1 = 0.05 P_1^2 + 20 P_1 + 800 \text{ Rs./Hr}$$

$$F_2 = 0.06 P_2^2 + 15 P_2 + 1000 \text{ Rs./Hr}$$

$$B_{11} = 0.01; B_{12} = B_{21} = 0.01; B_{22} = 0.024$$

(iii) Total Demand = 200 MW

**Operating limits:**

$$10 \text{ MW} \leq P_1 \leq 100 \text{ MW}$$

$$10 \text{ MW} \leq P_2 \leq 100 \text{ MW}$$

**Incremental cost function in Rs / hr**

$$dF_1 = 0.2 P_1^2 + 20 P_1 \text{ Rs./Hr}$$

$$dF_2 = 0.2 P_2^2 + 30 P_2 \text{ Rs./Hr}$$



**RESULT:**

Thus solution for economic dispatch and unit commitment problem for a given power system was solved using Mi – Power package and the results were presented.